



 LX Hausys

www.himacs.eu

HI·MACS

General Brochure 2022/2023

Great ideas made possible
with HIMACS



Solid Surface Material

Bar Paradise Now (page 41) - Multi to Flagship Stores (page 35) - Stoke Newington House (page 53)

HIMACS General Brochure 2022/2023

| | |
|-------------------------------|--------------|
| What is HIMACS? | Page 03 |
| HIMACS. Because Quality Wins. | Page 04 |
| Material Properties | Page 05 |
| Working with HIMACS | Page 06 |
| HIMACS Quality Club | Page 07 |
| Ecology and Recycled Colours | Page 08 |
| Hygienic Properties | Page 10 |
| HIMACS Collections | Page 11 – 27 |
| HIMACS Projects | Page 28 – 61 |
| LX Hausys Network | Page 62 |
| Specifications | Page 63 – 65 |
| HIMACS Colours | Page 66 – 69 |
| Sinks & Basins | Page 70 – 73 |
| Baths & Shower Trays | Page 74 – 75 |
| Contact | Page 76 |



Education and Cultural Places

Page 48 – 49



Living Spaces

Page 50 – 51



Kitchen

Page 52 – 55



Bathroom

Page 56 – 57



Airport

Page 58



Marine Industry

Page 59



Best of the Last Decade

Page 60 – 61



Public Buildings and Offices

Page 29 – 33



Shops and Exhibitions

Page 34 – 37



Façades and Wall Cladding

Page 38 – 39



Hospitality and Gastronomy

Page 40 – 44

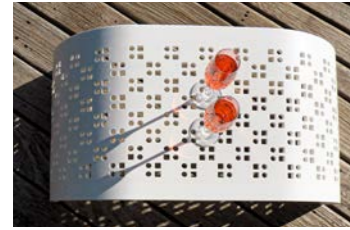

Outdoor, Furniture and Lighting

Page 45



Healthcare

Page 46 – 47

What is HIMACS?

An outstanding material.

HIMACS is a delicate composition of acrylic, minerals and natural pigments that combine to create a smooth, non porous, thermoformable and visually seamless surface.

The material meets the highest standards for quality in all respects: material performance, fabrication, functionality and hygiene. Thanks to these qualities and the outstanding flexibility in fabrication and design, HIMACS offers countless advantages over conventional materials.

And an ongoing inspiration.

We have gathered a number of projects here, all of which are capable of inspiring and creating a desire to tread new paths.

HIMACS. Because Quality Wins.

Photographed by Rafael Krötz



Quality is the longest warranty in the market.
We support our Quality Club Members with a 15 year warranty.

Quality is in our DNA.

HIMACS benefits from the high-tech infrastructure and development-experience of the LX Hausys who regularly bring stunning innovations to life. LX Hausys guarantees superior quality for all raw materials; the acrylic in HIMACS is produced by our own factories, certifying excellence from the source.

Quality is availability.

We stock the entire colour and product range in one European central warehouse and 40 local warehouses in Europe.

Quality is worldwide support.

Full access to LX Hausys after-sales support and fabrication network worldwide.



Quality is an excellent network of highly skilled craftsmen.

Our highly skilled fabrication partners enjoy regular training to provide you with the best possible product. They have access to the best in class training material and support. The most skilled fabricators of HIMACS are easy to identify as they are certified members of the HIMACS Quality Club. Contact us for your nearest member.

The excellent qualities of HIMACS at a glance.

Design

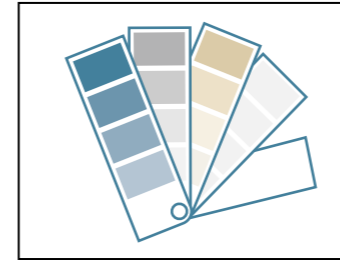

Huge colour spectrum

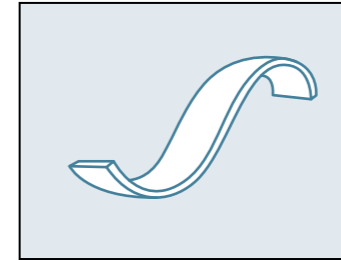

Three-dimensional design for complete design freedom

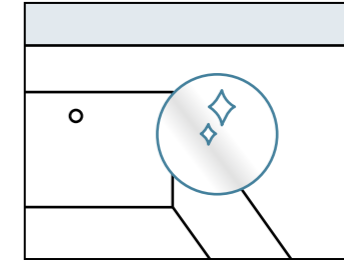

Visually seamless joining of sheets and flush installation of sinks and basins

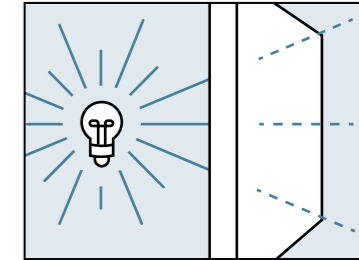

Spectacular light effects thanks to translucence

Performance



Robust and durable

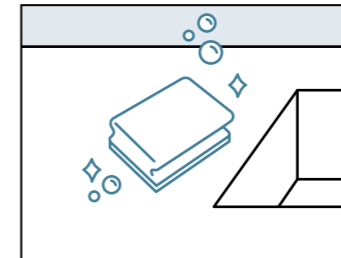

Easy cleaning and exceptional hygiene properties

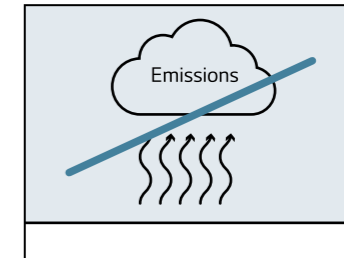

Free of emissions, formaldehyde and nanoparticles

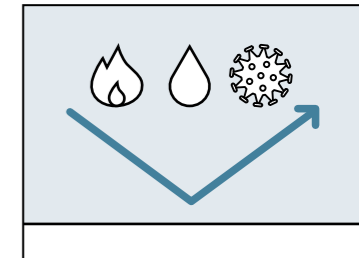

Fire-resistant, impervious to liquids and resistant to germs and chemicals

Fabrication

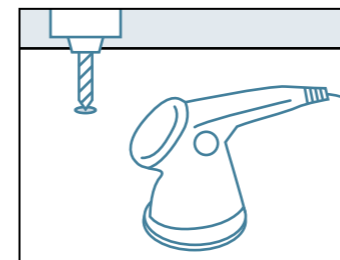

Easy to process with hardwood tools

Sustainability

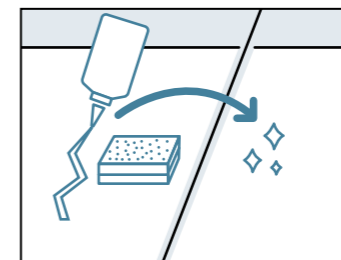

Easy to restore and repair

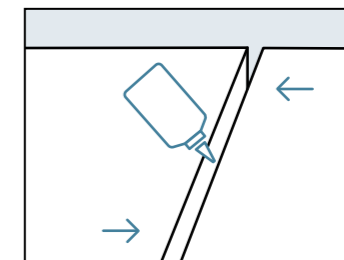

Off cuts can be reused reducing waste

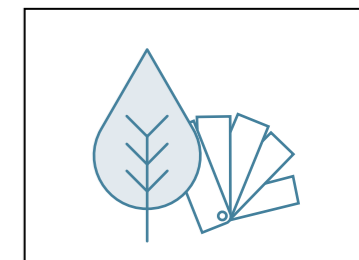

Recycled colours available

Working with HIMACS is easy.
Everything you need will already be in your workshop.



As a woodworking expert, you only need to open your workshop to find everything you need: talented craftsmen, and tools for working with hardwood. That's all you need to saw, drill and sand this material.

And if you have a pre-heating oven or a heating press, then you'll find it easy to heat the material for thermoforming. That's all there is to it: the carpentry workshop that once specialised in timber materials, is transformed in an instant into a company that can also offer modern stone products as well.

Welcome to the HIMACS Quality Club.

The members of the HIMACS Quality Club are our closest partners when it comes to working with the material and experiencing its tangible benefits:

- We train our partners with a comprehensive training programme, the best trainers and the best working manual.
- We cooperate closely with our Quality Club members on all material and work-related questions and guarantee comprehensive technical support.
- We also actively support our partners in sales, including forwarding specific project enquiries.
- Our partners benefit from our Europe-wide marketing and communication strategy: PR, traditional advertising, online communication, social media, as well as involvement in all the relevant industry events.
- Partners who belong to the HIMACS Quality Club are exclusively able to offer a 15-year material guarantee and thus gain a crucial competitive edge when pitching for projects.



Join the HIMACS Quality Club!
Certify your fabrication expertise by taking part in our Training Programme and become a HIMACS Quality Club Member.



Those who think green create an entire eco-system.

LX Hausys is a global pioneer in ecologically responsible action and consistently demonstrates this attitude. From production to transport and disposal, HIMACS meets the highest ecological standards, making it the model pupil of its kind.

©iStockphoto - 4maksym

Quality means thinking about tomorrow today.

- 1. **material composition:** HIMACS consists of 67% natural minerals, 30% finest acrylic and 3% natural colour pigments.
- 2. **material safety:** HIMACS is completely free of formaldehyde, VOC emissions and nanoparticles, ensuring particularly high indoor air quality.
- 3. **manufacturing process:** HIMACS is produced in an energy-efficient and resource-saving manner. This includes consistent waste reduction, the recycling of pre-industrial off-cuts and water savings. The production plants themselves – such as those in Cheongju (Korea) or Atlanta (USA) – also comply with all environmental guidelines.

4. **logistics:** Whether in transport or logistics, our selected partners meet the highest ecological standards.

5. **processing:** The material allows for virtually waste-free processing. In addition, HIMACS installations are extremely strong and durable. They can easily be renewed to their original appearance, meaning they don't have to be replaced, thus giving a positive long-term environmental footprint.

DGNB: German Sustainable Building Council [Deutsche Gesellschaft für Nachhaltiges Bauen]
 BREEAM: Building Research Establishment Environmental Assessment Method
 LEED: Leadership in Energy and Environmental Design

6. certificates, environmental product declarations and regular tests:

DGNB German Sustainable Building Council (DGNB)
 HIMACS has achieved quality level 4 of 4 – the best rating – for the local environmental impact of the overall product (2018). The DGNB system is a holistic and unique certification system for sustainable construction.

BREEAM Building Research Establishment Environmental Assessment Method (BREEAM)
 delivered by bre
 Among other ratings, the material complies with "Hea 02 Indoor Air Quality" for particularly good air quality. BREEAM is one of the world's most important global rating methods for sustainable architecture.

Leadership in Energy and Environmental Design (LEED)
 Is a standard voluntary system to certify high performance of buildings, from the US Green Building Council (USGBC). LEED certifies buildings using a credit system. Architects and planners using HIMACS for their project can claim EQ Credit for Low-Emitting Materials with the category Indoor Environmental Quality (EQ).

Environmental Building Certificate – Grade "outstanding"
 The Korean Air Cleaning Association certifies that HIMACS complies with the Korean regulations for environmental building materials.



The colour choice for a positive ecological balance.

Sustainable design through consistent recycling.

With HIMACS you not only have an infinite number of different shades to choose from, but you can also opt for a particularly sustainable design thanks to our range of recycled colours. HIMACS recycled colours are durable, colourfast, and easy to maintain. They offer the same outstanding properties and green credentials as our standard HIMACS, but in addition contains up to 16% of preconsumer recycled material and are certified by the SCS Global Services for stated recycled content.

Natural and sustainable colours

LX Hausys has particularly environmentally friendly solutions in its product range: the colour palette of natural and earth recycled tones can be found on page 68.

* Greenguard certification ensures that indoor products do not exceed the limits for chemical emissions.

** Leadership in Energy and Environmental Design (LEED) for more information see page 8.

- ◆ HIMACS recycled colours are also GREENGUARD* Certified for Indoor Air Quality.
- ◆ HIMACS recycled colours can provide LEED** credits in sustainable design.



You can find more information on this topic in our "The Sustainable Quality of HIMACS" brochure and on www.himacs.eu.

HIMACS. The solid surface material for a particularly hygienic environment.

Especially suitable for decontamination of dangerous viruses such as HIV-1 and SARS-CoV-2

No chance for dirt and pathogens.

HIMACS is resistant to mould, dirt, viruses, bacteria and numerous chemicals and has been internationally certified*.



Seamless production for easy cleaning.

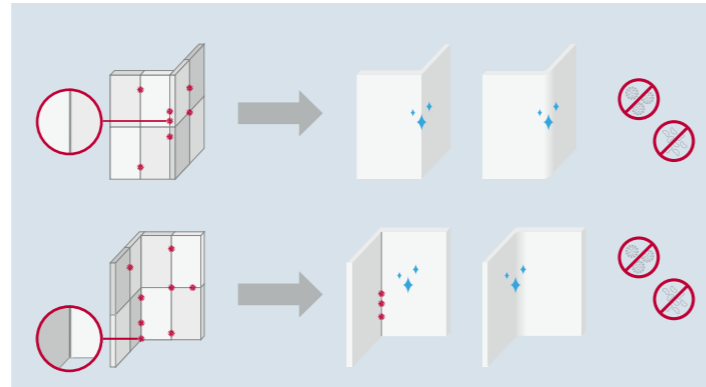

The hygienic properties of HIMACS.

Seamless, easy-care finish

HIMACS has a smooth, scratch-resistant and pore-free surface: liquids and germs cannot penetrate. Seamless processing prevents bacteria or mould from settling and enables thorough and quick cleaning so that cross-contamination and germs during treatments have no chance.

UV-C Disinfection method

The UV-C method is a physical sterilization procedure that utilizes UV rays. It kills microorganisms such as germs, viruses and bacteria quickly and effectively. The unique properties of HIMACS S828 UV+ allow the use of this highly effective method.

Chemical resistance

HIMACS can be maintained using the strongest detergents, from household chemicals to those used to clean operating theatres, while retaining a "like-new" appearance.

Functionality meets design

With its flexible formability and wide range of colours, HIMACS offers exceptional design possibilities and all the prerequisites for a sterile environment.

* certified by an independent laboratory, according to the international standards LGA and NSF

Further information on this topic can be found in our "Healthcare" brochure and at www.himacs.eu.

Niño Jesús Hospital, Madrid, Spain – Design: Elisa Valero – Fabrication: Muebles Maderama – Photo: Fernando Aida



The HIMACS Collections.

More than the sum of the parts.

MARMO COLLECTION

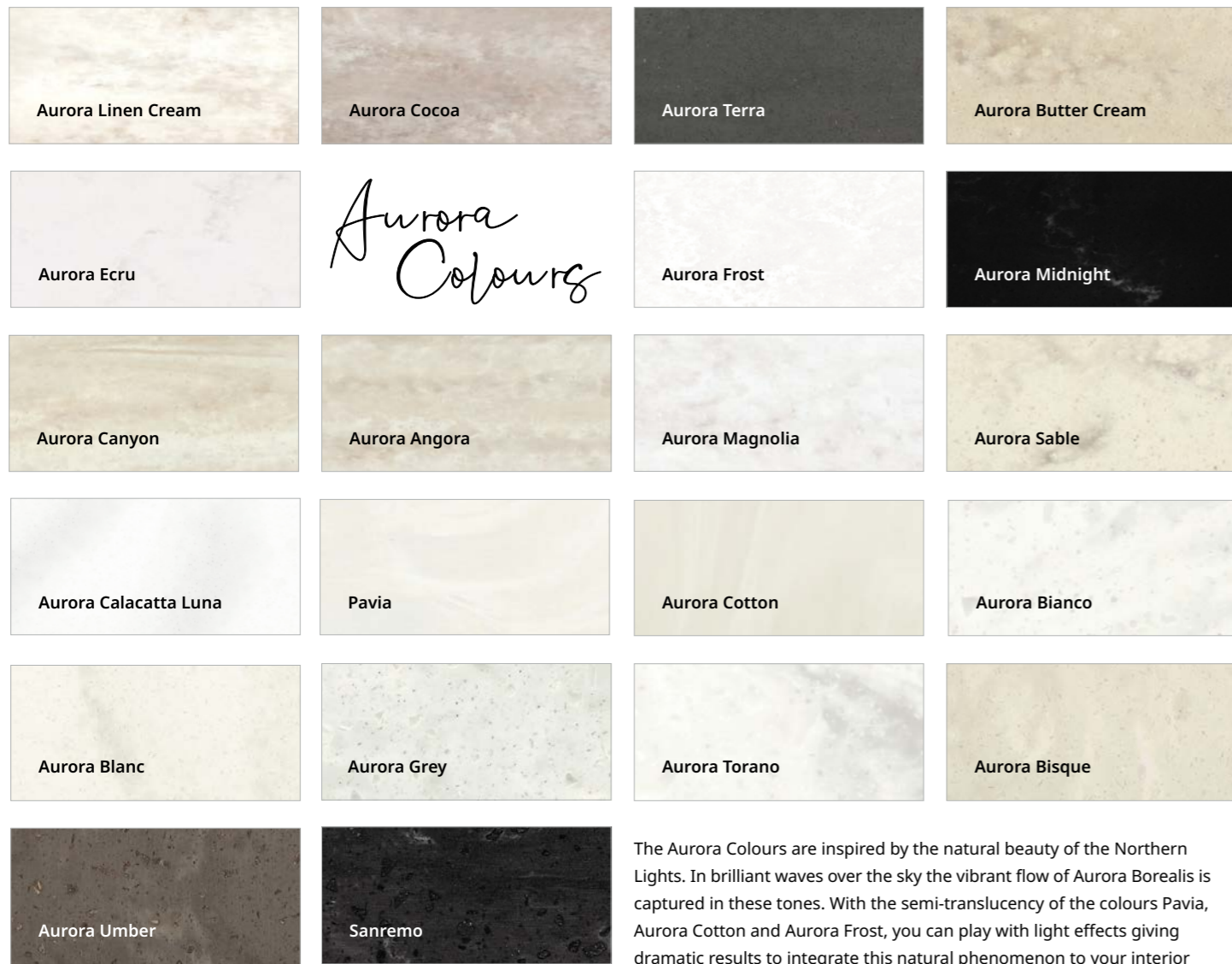

Aurora Colours

The Aurora Colours are inspired by the natural beauty of the Northern Lights. In brilliant waves over the sky the vibrant flow of Aurora Borealis is captured in these tones. With the semi-translucency of the colours Pavia, Aurora Cotton and Aurora Frost, you can play with light effects giving dramatic results to integrate this natural phenomenon to your interior design.

12 new Aurora colours – an evolution of the Marmo Collection – have been added to the range combining aesthetics inspired by nature with all the benefits of the latest generation solid surface HIMACS.

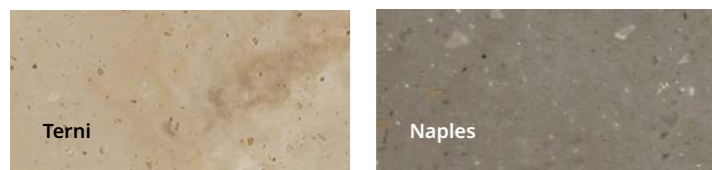

The HIMACS Marmo Collection provides colours to address the current trends for top-quality marble aesthetics, ranging from semi-translucent white, through shades of grey, to striking dark brown and anthracite tones.

MARMO COLLECTION

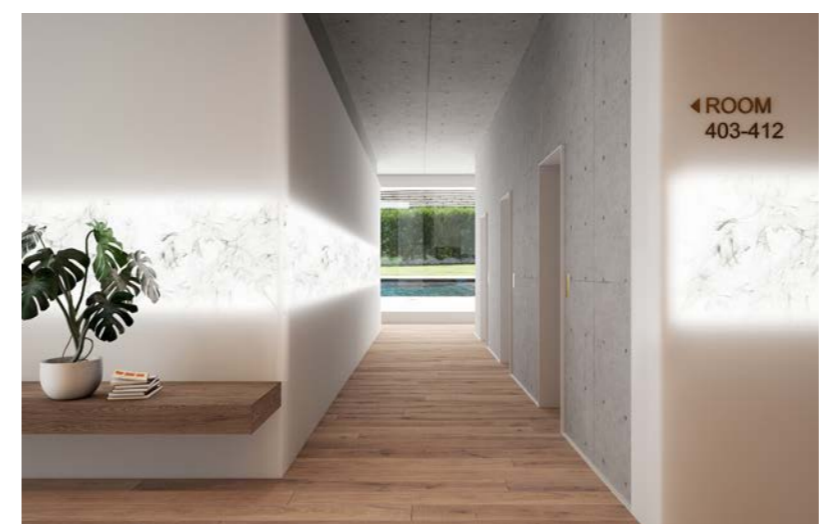
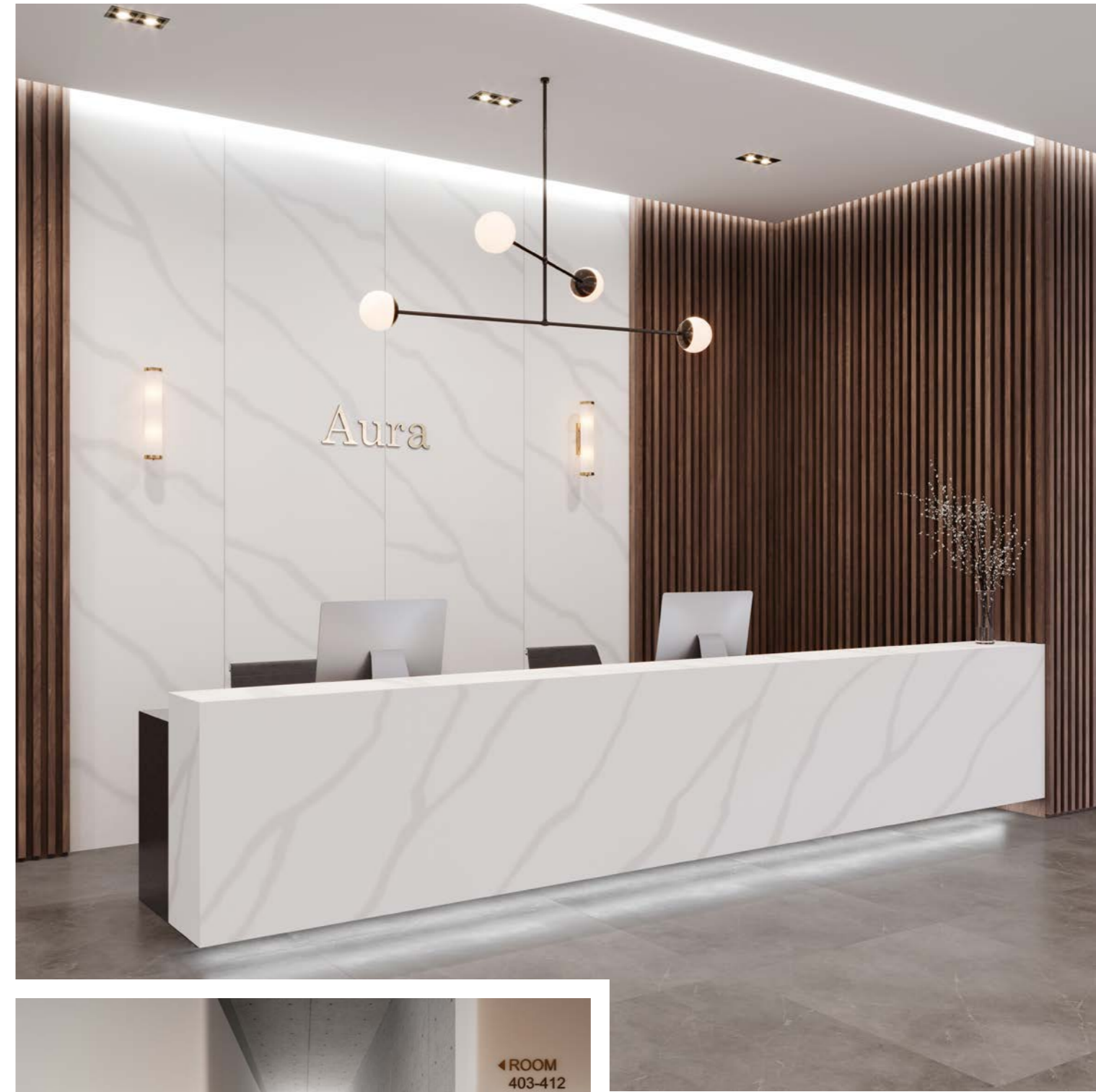

TERRAZZO COLLECTION

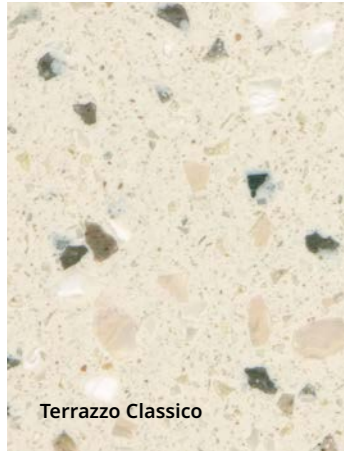

Terrazzo Classico

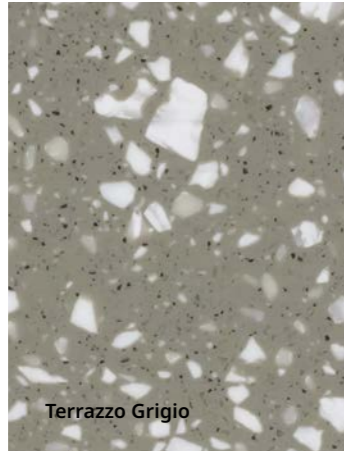

Terrazzo Grigio

Terrazzo has a long tradition as a material aesthetic: the coarse-grained look has offered the perfect blend of longevity and elegance since antiquity. HIMACS has now adopted the trend with two colours, which both combine perfectly with their typically coarse-grained, 'splattered' look. The Terrazzo Collection is especially suitable for the hospitality and gastronomy sector, as well as for any other high-traffic public building.



STRATO COLLECTION



Project: Family Home in Vrbaš - Location: Vrbaš, Serbia - Design: Architectural Studio Dekamerlar - Fabrication: Bane Doo - HIMACS Supplier: Bane Doo - Material: 2001, Strato Cloud - Photos: © Reja Ivanic



Strato Cloud



Strato Wind



Strato Slate

The Strato Collection enhances the HIMACS colour range with brand new design possibilities: the striations create geometry through its soft structure and subtle look. The skilful use of the new linear pattern, vertically or horizontally, allows for great variation in each and every project.

CONCRETE COLLECTION

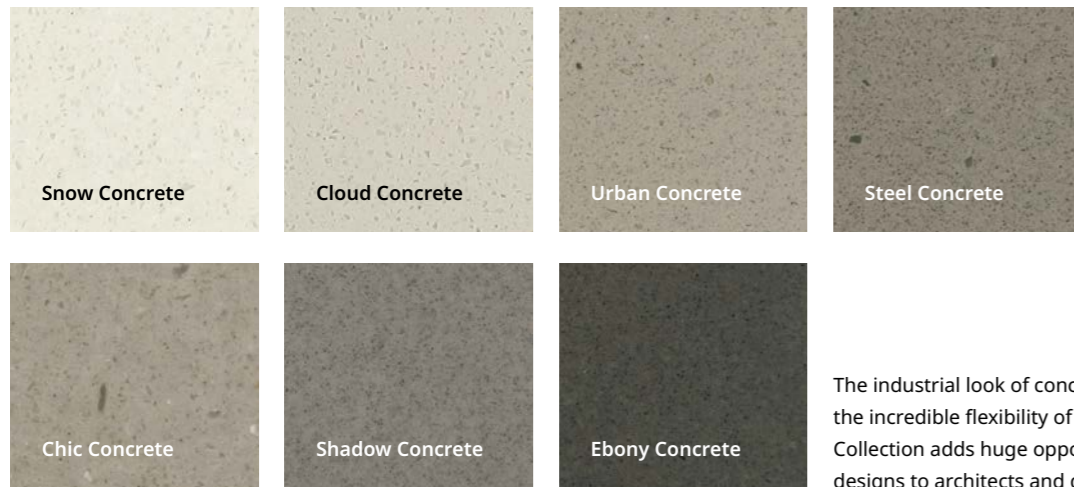

The industrial look of concrete combined with the incredible flexibility of HIMACS. The Concrete Collection adds huge opportunities for great designs to architects and designers.



LUCIA COLLECTION



This collection focuses on the natural trend colours black, white and grey. The lively and homogeneous structures add character and expression to the colours. Not surprising, as the renowned Dutch designer, Marcel Wanders, designed three of these colours.

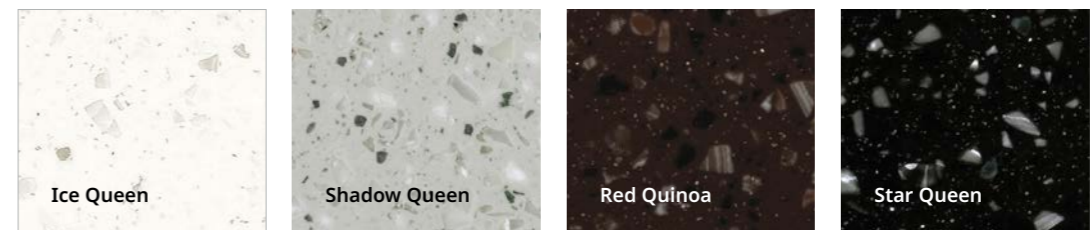

VOLCANICS COLLECTION

The large particles of the Volcanics shades add a sense of style to any design. When used on a large scale the result is a dramatic showpiece.

Three colours from the Volcanics range contain recycled content for an environmentally friendly solution with a luxurious natural stone look.

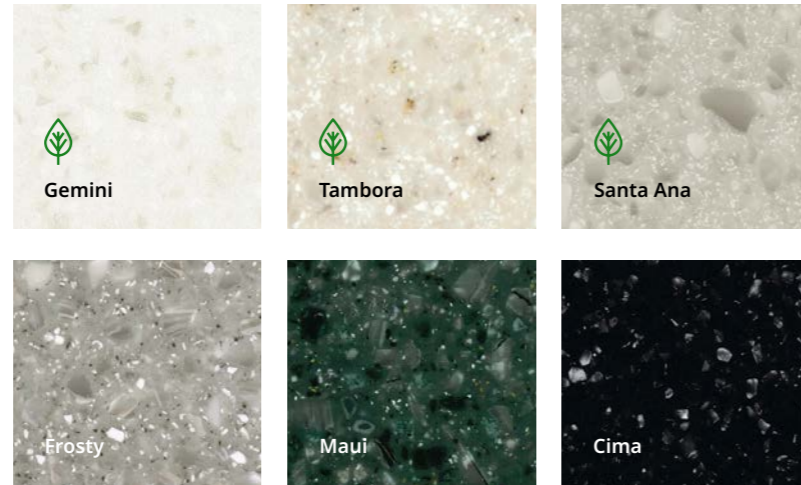

LUCENT COLLECTION

Translucency and effective use of light are decisive design elements of contemporary architecture – the shades of the Lucent Collection, with their exceptional light translucency, allow for spectacular designs. Whether effectively backlit or simply illuminated, the Lucent colours of the architecture always add an elegant touch thanks to their characteristic reaction to light.

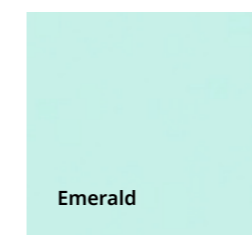
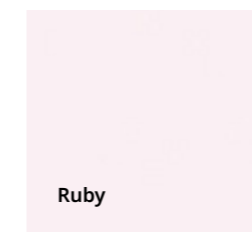

Oblique Men - Design: The Invisible Party - Fabrication: Van Assem Interieurbouw - HIMACS Supplier: Baars & Bloemhoff, The Netherlands - Material: HIMACS Emerald - Photographed by Sal Marston Photography

Raffaelsen Bank Meridrisio - Design by Studio d'architettura Casali Sagli - Fabrication: Il Falegname Fabrizio Sagli - Material: HIMACS Opal - Photographed by Claudio Bader

SOLIDS COLLECTION



The classic in terms of solid surfaces – a wide range of attractive shades of white lies at the heart of this collection. Complemented by colourful, dynamic uni-shade accents from Orange to Light Green. The timeless collection offers the perfect colour for every design.



Design: Herrmann Flavio – Fabrication: IL Falegname Fabrizio Saggi – HIMACS Supplier: Klausler acrylstein ag, Switzerland – Photographed by Claudio Bader

ASTER COLLECTION



Studio Podrini - studiopodrini.com

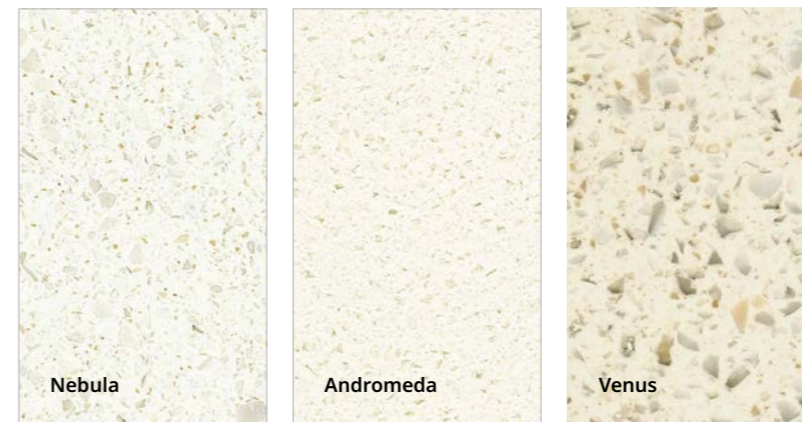

Aster is a collection of elegant shades of grey, ranging from almost white to a dramatic dark grey, all with a gorgeous mother of pearl shimmer.

GRANITE, QUARTZ, SAND & PEARL COLLECTIONS

Ultimate elegance thanks to lively textures, harmoniously natural tones and maximum subtleness. The Sand & Pearl, Granite and Quartz collections are perfect either alone or in combination with other colours.

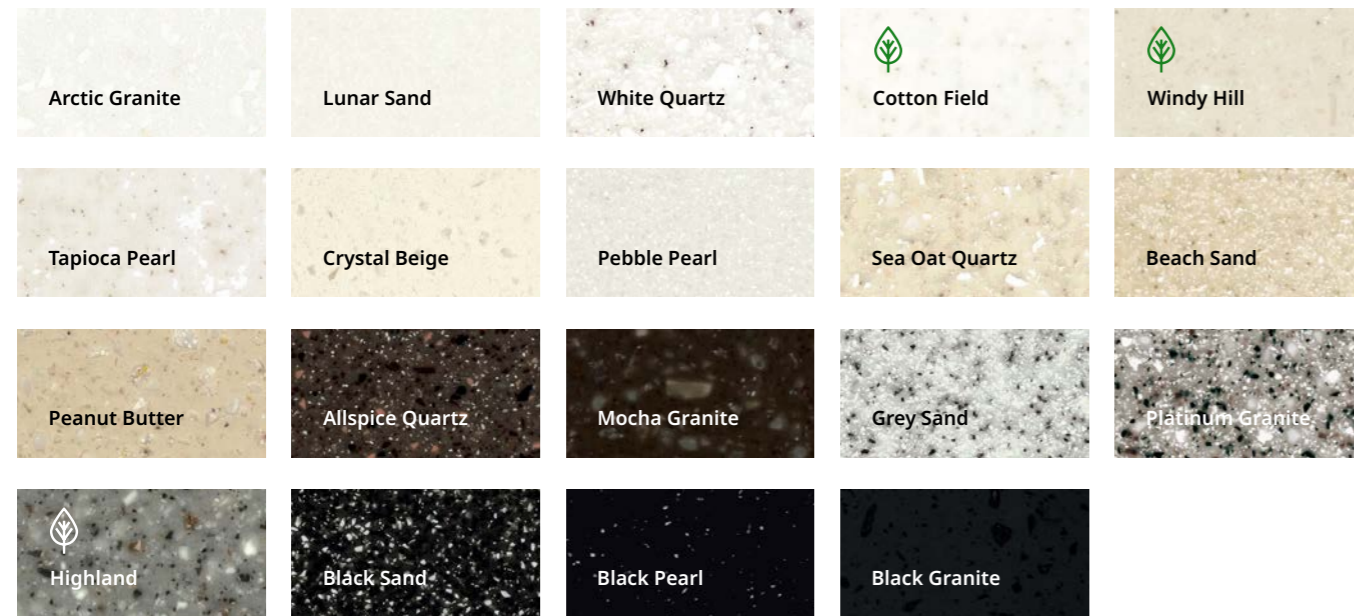

HIMACS EXTERIA®



For years, spectacular façades have been made from HIMACS all over the world. In doing so, the advantages are often skilfully staged: artistic relief milling with typography, flush mount company logos, backlit patterns and other spectacular light effects and curvy designs. And every good design inspires even more creativity.

With HIMACS Exteria®, LX Hausys is now expanding exterior possibilities.

- S728 HIMACS-FR (Alpine White) is the fire resistant formulation, which for many years, has offered increased fire resistance – certified by the ETA.
- S828 HIMACS-UV+ (Alpine White) is the new exterior formulation offering even better UV resistance, which is particularly important when the façade is exposed to high levels of sunlight.
- All other HIMACS colours labelled with a sun symbol can also be used outdoors. You can find these on pages 66 to 68.

HIMACS Exteria® Certificate



Fixed with KEIL inserts and a BMW structure, HIMACS façade in S728 – Alpine White successfully passed the ETA tests (European Technical Agreement).



HIMACS Ultra: Darker, more intense, free-form, wow!



Permanent innovation leads to tangible benefits

Today's designers want to exhaust all options: to realise spectacular forms with intense, sensual tones. They want to realise more than function with their design: they want to convey emotion, energy and enthusiasm.

HIMACS Ultra has been developed precisely for this purpose. Particularly intense shades – from radiant Alpine White to the ultra-dark shades Intense Ultra Grey, Intense Ultra Dark Grey or Intense Ultra Black – plus advanced thermoforming properties and significantly greater robustness. The advanced Thermoforming has clear advantages, especially in bathrooms and furniture design: the radii of individually designed pieces can be made significantly smaller, which has a positive effect on the look and size of the object.

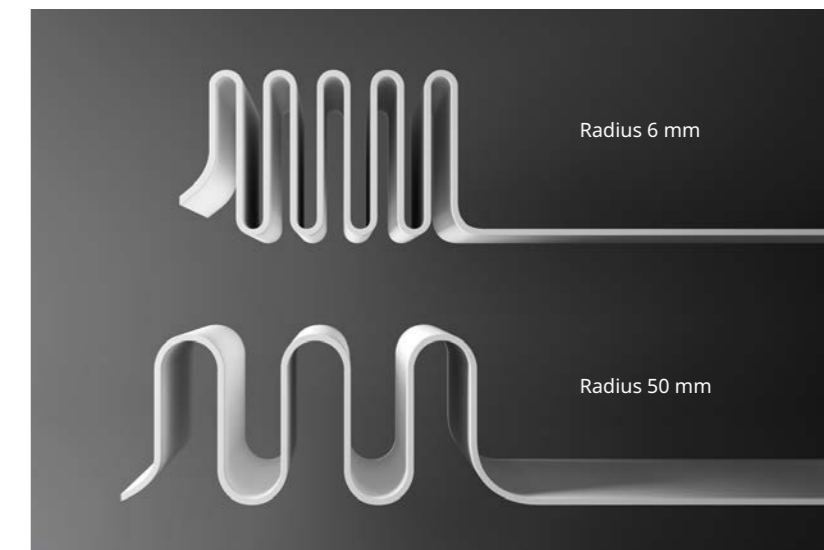

The HIMACS Ultra sheets can be shaped even better: The minimum inner radius of 6 mm (conventional 50 mm) offers a completely new design dimension. The 30% higher flexibility allows the designer to create significantly sharper curves. Even the smallest radii can be achieved without affecting the material properties.



Intense Ultra Grey



Intense Ultra Dark Grey



Intense Ultra Black



Ultra-Thermoforming Alpine White

Perfect for kitchen, laboratory and bathroom.

The comprehensive range of sinks, basins, baths and shower trays available in HIMACS, means creative planners have all the options to design functional and tasteful kitchens and bathrooms, sanitary facilities, hospitals and much more. With the exception of some countertop bathroom bowls, all these products are designed to be flush- or under-mounted, in combination with HIMACS sheet materials.



The coordinated sinks can be installed flush- or under-mounted. The result is extremely hygienic, easy to maintain units from a single cast. Perfect for the kitchen and laboratory.

HIMACS SINKS, BASINS, BATHS & SHOWER TRAYS



All images on this page: Studio Podrini, studiopodrini.com



The new shower trays and baths from HIMACS offer a pleasant, warm touch and silky matt elegance. Three shower trays and three baths extend the product offering for classy and elegant bathrooms.

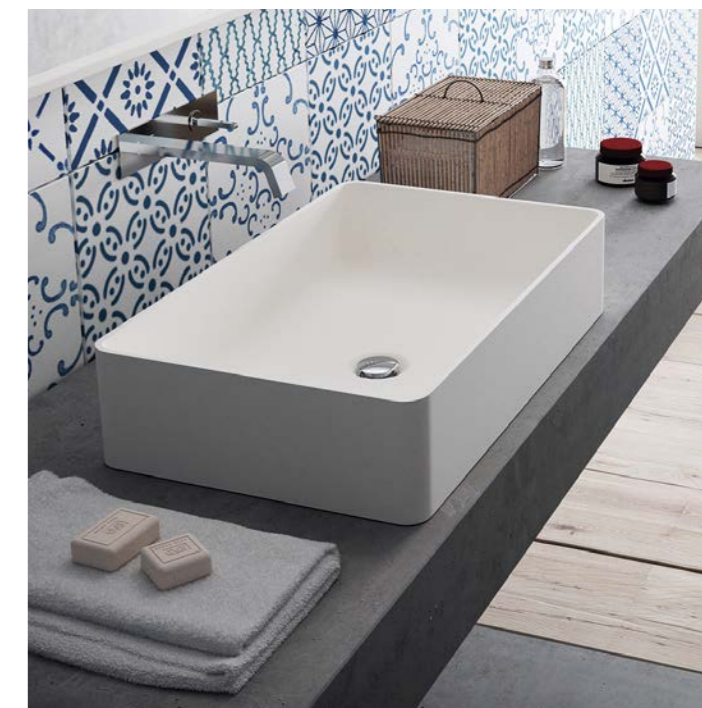

In addition, the HIMACS top-mounted range offers three exclusive countertop basins that perfectly capture the trend of linear bathroom designs.

HIMACS Projects

Exciting ideas, spaces and installations from Europe.

Public Buildings and Offices

The requirements for public spaces are very demanding. It's therefore good to know that HIMACS regularly undergoes all of the relevant product tests and holds all the required certificates to prove its superior quality.



Bus station

Location: Weilheim in Oberbayern, Germany

Design: Atelier PK Architekten, Germany, atelier-pk.com

Fabrication: Roskopf + Partner AG, Germany, roskopf-partner.com

HIMACS Supplier: Klöpfer Surfaces

Material: HIMACS Opal

The highlight: the translucent band made of HIMACS

The all-round cladding of the roof edge gives the roof construction of this bus station a bright and elegant frame. As a special design effect, the elegant lettering "ZOB Weilheim" was milled and backlit in two places of the circumferential band, made possible thanks to the translucent properties of the solid surface material used here in the shade Opal.



The place name has been discreetly milled into the material here and gives the light band even more character.



HIMACS "Pavia" matches the other materials perfectly and was used for desks, surfaces of sideboards, shelves, door handles and knobs as well as for the bathroom basins.

Headquarters Davos&Co. and Horizon Building Inc.

Location: Porto, Portugal
Design: Ricardo Rios / Fernando Brandão Alves from Edição Limitada – Arquitetura e Design LDA – edicaolimitada.pt
Fabrication: JRconcept / Alumina Design
HIMACS Supplier: Banema
Material: HIMACS Pavia

The hygienic, antibacterial properties of the material, the ability to process it in many different shapes, the translucent aesthetics and the delicate, soft feel made HIMACS the ideal material for the diverse applications at the headquarters of this Portuguese construction group. For the bathrooms, for example, each basin and countertop was made in one piece in the colour Pavia. These are backlit, giving the washbasins a delicate and mystical appearance.

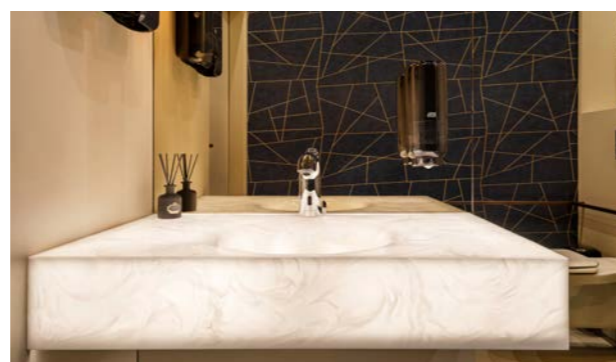
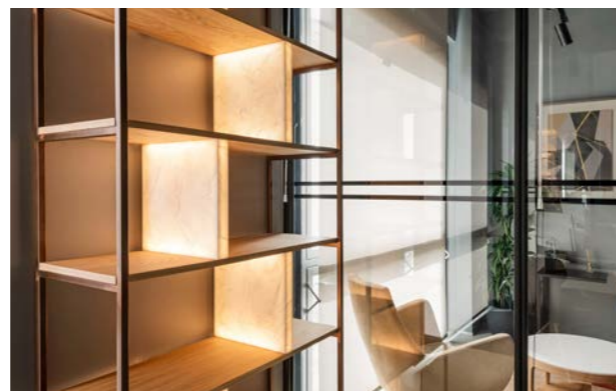

Beautiful and functional: the central element of this showroom is both a sculpture and a co-working table.

Arredi Lab Showroom

Location: Comiso, Ragusa, Italy
Design: DFG Architetti Associati, Italy, dfgarchitetti.it
Fabrication: Arredi Lab by Porte Più, Italy, arredilab.net
HIMACS Supplier: Primek di Paola Provenzano
Material: HIMACS Alpine White

The ability to use light in different ways is one of the special properties of HIMACS: the geometric surfaces of this desk sculpture are illuminated from different directions and make it look different from every angle. The almost unlimited design properties of HIMACS allow even the most eccentric designs to become a reality.



All images on this page: Photographed by Wouter van der Sar Photography



Pathé Cinema Leeuwarden

Location: Leeuwarden, The Netherlands
Design: Pathé Paris, France
Fabrication: Van Der Plas Meubel & Project BV, The Netherlands, vanderplas.biz
HIMACS Supplier: Baars & Bloemhoff
Material: HIMACS Alpine White, Banana

In the cinema, light traditionally plays the leading role
The cinema is a place of magic. At the same time, it is a very high traffic area. These two factors result in requirements that HIMACS easily meets. The colourful counters and wall elements here are reminiscent of American cinemas of the 1950s, and they are extremely easy to clean and are resistant to dirt and germs due to the seamless finish throughout.



The large, flush-mounted hall numbers are illuminated from behind to aid orientation in a discreet way.



AOK reception desk

Location: Nürnberg, Germany
Design: Aura GmbH
Fabrication: carpenter cooperation Bodenschlägel GmbH & Co. KG, Bezold GmbH & Co. KG, Bert Lenz Möbelmanufaktur GmbH
HIMACS Supplier: Klöpfer Surfaces
Material: HIMACS Alpine White

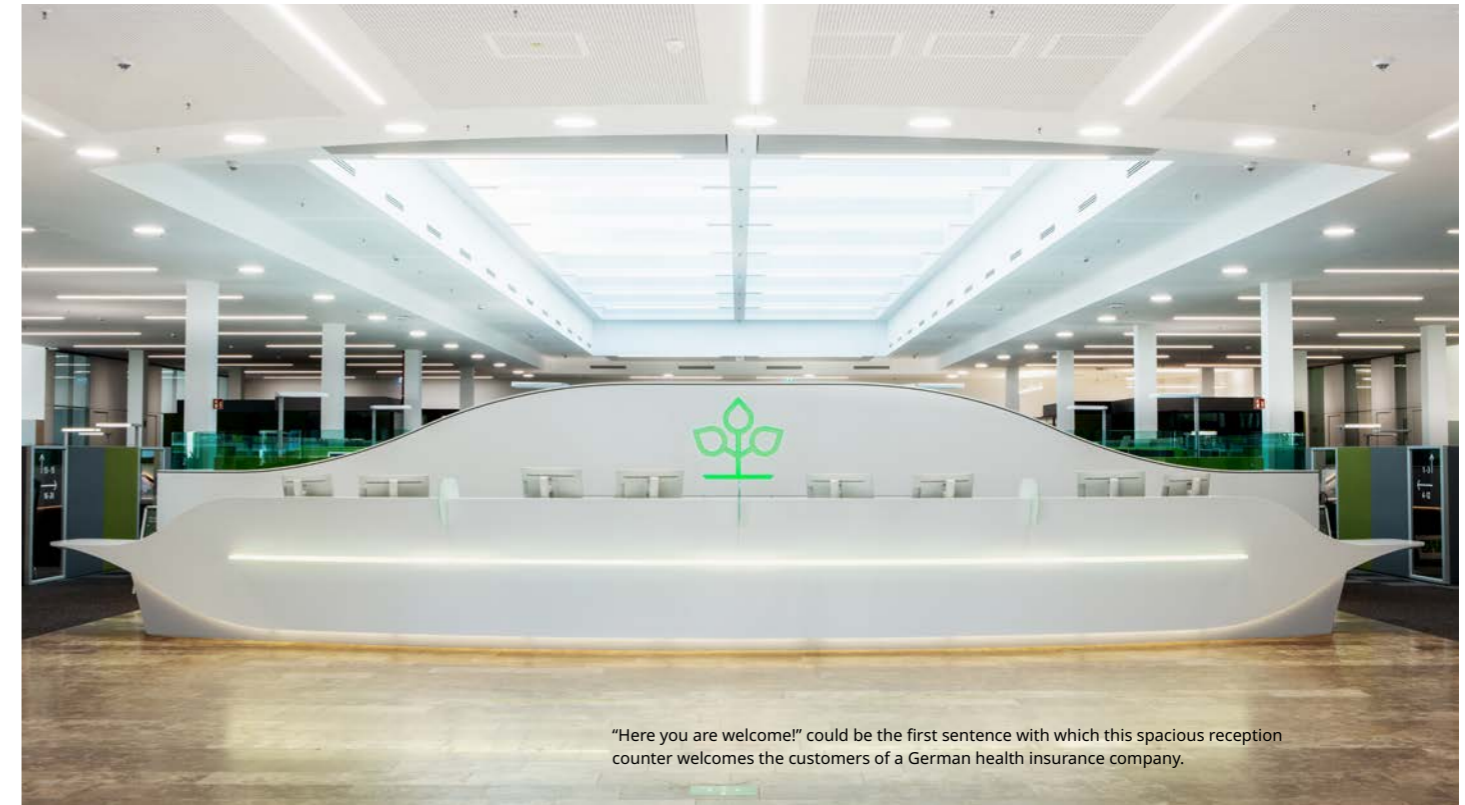

"Here you are welcome!" could be the first sentence with which this spacious reception counter welcomes the customers of a German health insurance company.



The first impression is made by a buoyant brand ambassador
When a building calls for a material that can be processed on a large scale and with confidence, you quickly end up with HIMACS. The elegant sweep, combined with subtle lighting and the centrally inserted brand logo, gives the reception counter a real feeling of quality.

All images on this page: Photographed by Ralf Munker

Shops and Exhibitions

It is an accepted fact in retail, that no compromises can be made in terms of quality. And HIMACS does just what the high-tech brand LX Hausys promises. With its limitless possibilities, the material meets the demanding requirements to perfection.

Hairdresser Denny K

Location: Berlin, Germany

Design: Poschmann Design GmbH, Germany, poschmann-design.de

Fabrication: Holztec Innenausbau GmbH, Germany, tb-berndt.de

HIMACS Supplier: Klöpfer Surfaces

Material: HIMACS Black



All images on this page: Photographed by Sandra Künnapfel

The modern, geometric interplay of forms of this elegant black counter, with the accentuated edges in gold, contrasts perfectly with the floral back wall. The counter made of HIMACS gives this room contour and character.



Charming play with contrasts: the angular counter combines noblesse with functionality.



The Scandinavian design brand Muuto relies on the aesthetics of HIMACS. Especially in commercial use, the core properties of HIMACS are crucial: the material is extremely durable, hard-wearing and resistant to wear and tear, weather, fire and UV rays. The non-porous surface makes HIMACS completely waterproof and easy to clean. The seamless finish results in a smooth, uniform appearance and prevents dirt, bacteria and viruses from settling on the surface. In short: All of this has inspired the designers at Muuto.

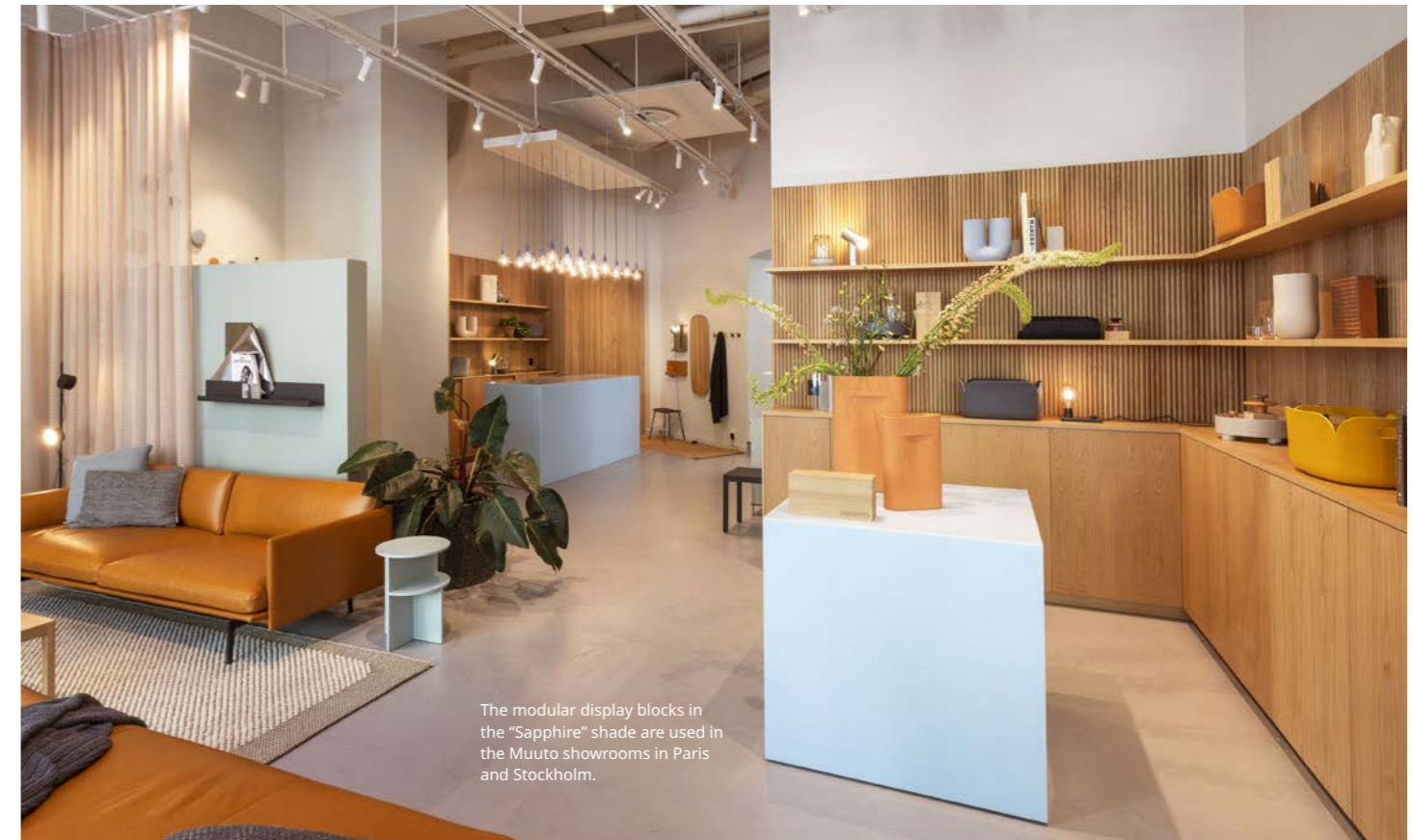

The modular display blocks in the "Sapphire" shade are used in the Muuto showrooms in Paris and Stockholm.

All images on this page: Photographed by Muuto



Muuto Flagship Stores

Location: Paris and Stockholm

Design: Muuto, muuto.com

Material: HIMACS Sapphire and Alpine White



HIMACS masters large and small stages

It is not a question of size, but of skilful design and workmanship. Even in a small space, HIMACS shows off many of its advantages. Here the individual arrangement of the storage boards, the discreetly accentuated colouring of the counter and also the backlit product presentation give this checkout area of a hairdressing salon its own character.

hairdresser

Location: Berlin, Germany

Design and Fabrication: Frank Kaiser
Objekteinrichtungen, Germany,
kaiser-objekt.de

HIMACS Supplier: Klöpfer Surfaces

Material: HIMACS Alpine White, Opal



The backlighting of the rear wall creates the perfect stage for the products on display.



All images on this page: Photographed by A.M.O.S. DESIGN s.r.o.

The curved borders of the furniture and planting elements lend structure and precision to the expansive space.

The furniture and plant elements in this food court of a modern mall are all made of Alpine White HIMACS. The objects all invite people to interact with them: customers sit on them, put bags and objects down. HIMACS is perfect for this use. Robust, easy to clean and easy to repair if the worst comes to the worst.



Nivy Mall

Location: Bratislava, Slovakia

Design: Siebert Talass, sieberttalass.com,
developed by HB reavis Slovakia

Fabrication: A.M.O.S. Design s.r.o.,
Czech republic, amosdesign.eu

HIMACS Supplier: Polytrade CE, s.r.o.

Material: HIMACS Alpine White

Façades and Wall Cladding

HIMACS superior quality makes it ideal for using in cladding projects, facades and wall linings.

Spektrum Shopping Centre

Location: Prague, Czech Republic

Design: Chapman Taylor Architects, Czech Republic, chapmantaylor.com

Fabrication: A.M.O.S. Design s.r.o., Czech Republic, amosdesign.eu

HIMACS Supplier: Polytrade CE, s.r.o.

Material: HIMACS Alpine White



All images on this page: Photographed by Chiara Cesana

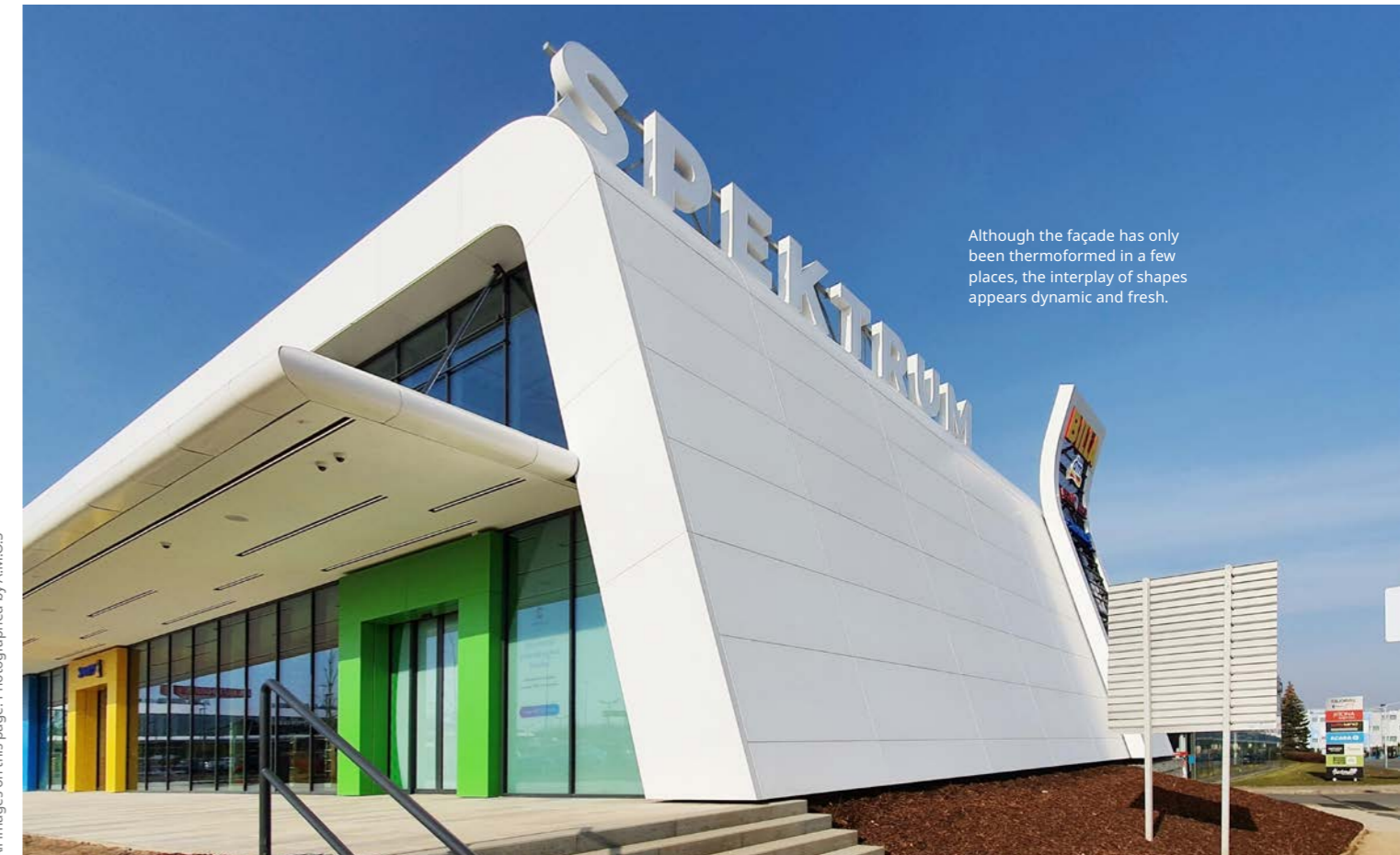

All images on this page: Photographed by A.M.O.S

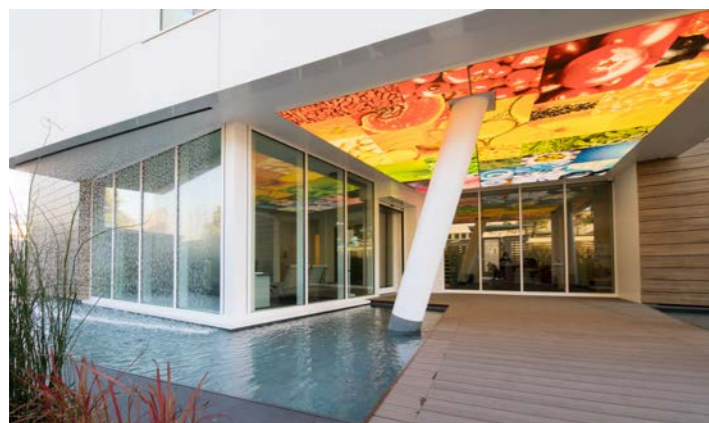

For the company "LongLife", HIMACS was the perfect choice thanks to its extreme resistance to external influences. Thanks to its homogeneous and non-porous surface, the material is resistant to moisture, UV rays and temperature fluctuations. In addition, the fact that HIMACS is the first solid surface material on the market to receive the ETA (European Technical Approval) certificate for exterior façades in the colour Alpine White S728, made the decision even easier.

LongLife Headquarters

Location: Peschiera Borromeo (Milan), Italy

Design: Fernando Fantetti, Italy

Fabrication: Andreoli Srl, Italy, andreolisrl.com

HIMACS Supplier: Arplast Laminati Srl

Material: HIMACS Alpine White



This shopping centre in Prague, Czech Republic, has been completely rebuilt. A major part of on the completely new appearance is the exterior: the HIMACS façades constructed in radiant Alpine White give the building a modern and attractive finish.



Hospitality and Gastronomy

HIMACS creates visual, statement features in the trendiest of bars, the most upmarket of restaurants and the most happening clubs. Especially for internationally operating hospitality chains it is good to know that LX Hausys offers a global after sales service with their network-partners.



Most Innovative Project



A dream place of light and lightness

When design and art merge, spaces are created that communicate emotionally. The architects of this lovely bar have succeeded in the best possible way. The customers become part of the stage, reveling in the fabulous art deco surroundings with the dramatic lighting effects.

HIMACS is a decisive building block for this quality of experience: the magical translucency, the soft feel and the entire package of good gastronomic properties made the decision to use HIMACS easy.

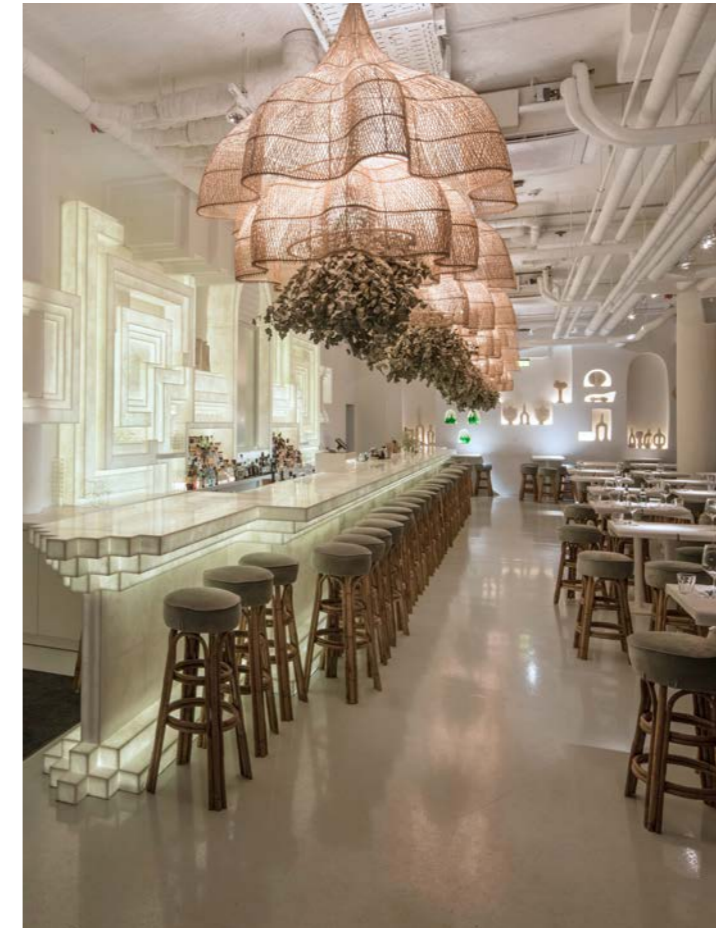

Bar Paradise Now

Location: Dusseldorf, Germany

Design: Moritz von Schrötter, Charles Bals, Walid El Sheikh

Fabrication: Schreinerei Karl Heller GmbH, Germany, schreinerei-heller.de

HIMACS Supplier: Becher GmbH & Co. KG

Material: HIMACS Ispani, Arctic White, Black

The elegance of the backlighting is further enhanced by the soft texture of the Ispani shade.



All images on this page: Photographed by Rainer Reifeld

1841 coffee and espresso bar

Location: Glasgow, Scotland
Design: Susanne Sharif, Scotland
Fabrication: Simon Harlow, Scotland
HIMACS Supplier: James Latham
Material: HIMACS Terrazzo Classico



Let's have an espresso on HIMACS!
 Thomsons Coffee Roasters was founded in Glasgow, Scotland, in 1841. The coffee brand's new coffee and espresso bar is a successful blend of modern, minimalist and traditional elements. The counter top is made of HIMACS in the Terrazzo Classico colour, which perfectly complements the details of the traditional materials of wood and glass. In addition to aesthetics, hygiene, cleanliness and ease of use were of utmost importance to the owners.



El Txoko de Martín

Location: Palma, Mallorca, Balearic Islands, Spain
Design: Juan Chito, Spain
Fabrication: Sublime – Grup Concord, Spain, concordimpresion.com
HIMACS Supplier: Panelwork
Material: HIMACS Alpine White

Star cuisine meets high-tech art

The murals in this top Spanish restaurant were produced by means of elaborate sublimation on HIMACS panels in the colour "Alpine White". In this process, digital prints are transferred to the solid surface in a gaseous state through controlled pressure and heat in special ovens. The images were thus fully integrated into the material to make the artwork properly robust. The completely smooth HIMACS surface guarantees the perfect finish for the colour.



When guests enter this casual new restaurant by the Spanish star chef Berasategui, the murals with sports motifs immediately catch their eye.

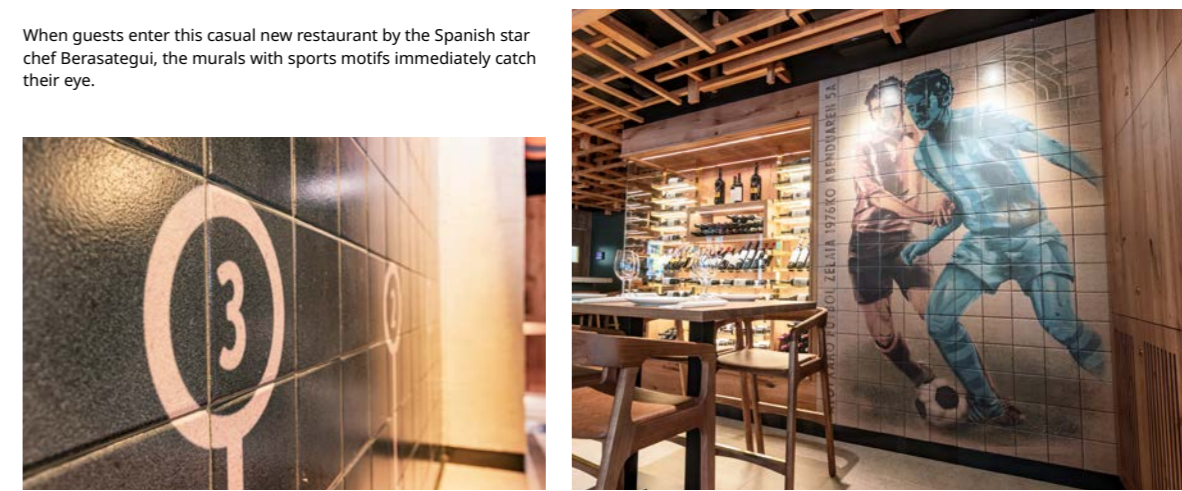

German Doner Kebab

Location: United Kingdom
Design: O1 Creative, United Kingdom, o1creative.com
Fabrication: Paradigm Woodworking Specialists, United Kingdom
HIMACS Supplier: James Latham
Material: HIMACS Cima



Outdoor, Furniture and Lighting

Designer accents and maximum functionality: experts in furniture and lighting choose HIMACS when the extraordinary is to succeed. And for interior and outdoor areas HIMACS copes perfectly with all weather and UV conditions. The material has passed all the necessary tests with selected colours, proving that outstanding quality defies the toughest outdoor conditions.



Good solutions can be so simple: this chic storage table was made from a rectangular piece of HIMACS: thermally formed, the pattern was created with a CNC router et voilà: the designer piece is finished.

Arche

Location: Royan, France
Design and Fabrication: Kazéhana & Tuillière, France, kazehana-tuilliere.com
HIMACS Supplier: Planacryl
Material: HIMACS Alpine White



Palma

Location: Vaux sur Mer, France
Design and Fabrication: Kazéhana & Tuillière, France, kazehana-tuilliere.com
HIMACS Supplier: Planacryl
Material: HIMACS Alpine White

This column is a piece of craftsmanship in the best sense of the word: the individual design of the ears of corn was drawn by hand and milled into the object thanks to CNC technology. Perfectly illuminated, this atmospheric outdoor sculpture is a work of art.

A perfect kebab needs a perfect environment

HIMACS Cima is a colour that fits perfectly into the natural design trend of the moment. Here, the table surfaces and parts of the wall coverings in Cima are used in combination with natural stone, wood and leather. HIMACS is the perfect material for high traffic areas, and its ultra-cleanliness property is just right for areas requiring immaculate hygiene.



The finish of the tables is high-gloss to add elegance to the installation.



Photographed by Heilmüt-Specht



Table football

Location: Raisting, Germany
Design: Kersteiner Schreiner Meisterschule München / Dreer+Graf / Simon Heinold, Germany, meisterschule-schreiner.de
Fabrication: Dreer+Graf, Germany, dreer-graf.de
HIMACS Supplier: Klöpfer Surfaces
Material: HIMACS Alpine White

It's no coincidence that this football table is in a German master carpentry school. The HIMACS surface has the perfect smooth, soft feel, and also allows the curved design of the supporting frame.

Healthcare

Cleanliness and sterility are paramount in hospitals and laboratories and any materials used should meet the strictest quality-standards. Its internationally certified resistance to dirt, viruses, bacteria and numerous chemicals makes HIMACS the first material of choice in the healthcare sector.

Zahnärzte am Stadtpark

Location: Hamburg, Germany

Design and Fabrication: Oer Inneneinrichtungs- und Ladenbau GmbH, Germany, oer.de

HIMACS Supplier: Becher GmbH & Co. KG

Material: HIMACS Arctic White, Urban Concrete

Where design and business model speak the same language

A dental practice requires high standards of hygiene: the surfaces of the laboratory tables and treatment furniture, which are subject to mechanical and chemical stress, are therefore made with HIMACS. In the spacious reception area, which takes up a visual 'tooth' theme, the look is clean and inviting thanks to HIMACS again.



Hygienic, friendly, welcoming.

Within a medical practice, the reception has the task of conveying a good first impression. This is where the understanding of professionalism, friendliness and taste is subtly conveyed, which every customer perceives – consciously or unconsciously. The counter of this dental practice radiates a high degree of clarity and perfection. The backlit band and the indirect light emission on the floor give the central counter furniture its special charisma.

Dental Surgery

Location: Immenreuth, Germany

Design & Fabrication: Bezold GmbH & Co. KG, Germany, bezold-innenausbau.de

HIMACS Supplier: Klöpfer Surfaces

Material: HIMACS Alpine White



Besides the dominant reception counter, HIMACS is used in many places: as shelf furniture, and also in laboratories and treatment rooms.

Education and Cultural Places

The extreme toughness and ease of maintenance from HIMACS are prerequisites to withstand everyday life in nursery schools, schools, universities and other institutions.



All images on this page: Photographed by Peter Schrijnen 2021 - Provincie Limburg; www.Limburg.nl - OMA - The Image of Europe



The graphic museum installations get to the heart of the central issues of the EU.

Exhibition on the Treaty of Maastricht

Location: Province of Limburg, Maastricht, The Netherlands
Design: Maurice Mentjens, The Netherlands, mauricementjens.com
Fabrication: Curfs Interieurbouw, The Netherlands, curfsinterieurbouw.nl
HIMACS Supplier: Baars & Bloemhoff
Material: HIMACS Ivory White

In a place steeped in history, one relies on HIMACS
 The modern designer rooms in Maastricht recount decisive moments in European history. The furniture is a mixture of perfect and discreet function whilst still having an aspirational feel. HIMACS can do both: it is able to withstand the wear and tear of high traffic areas, but can also showcase designers' wildest dreams.

Between Space and Surface

Location: Biennale, Venice, Italy
Design: Ludovico Bomben, Italy, ludovicobomben.com
Fabrication: Dform SRL - THEKE, Italy, dform.it
Material: HIMACS Alpine White

The boundaries between art and architecture become blurred when renowned artists such as Ludovico Bomben work artistically with HIMACS as is the case for the Architecture Biennale. Here HIMACS serves as a "canvas" for the application of his objects, made of gold leaf and other materials.

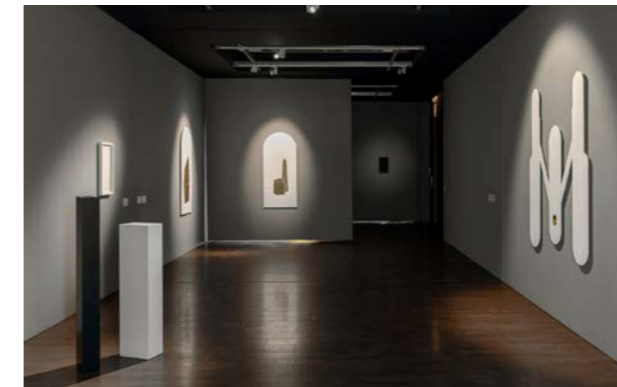

Experimenta

Location: MS experimenta, Germany
Design: zwo/elf, zwo-elf.de - Schreinerei Wimmer-Huber (Interior fittings), wimmer-huber.de
Fabrication: Hasenkopf Industrie Manufaktur, Germany, hasenkopf.de
HIMACS Supplier: Klöpfer Surfaces
Material: HIMACS Midnight Grey

Where young minds experiment with heart and hand, a solid material is needed.
 "Experimenta" invites young people to get involved in technical experiments. There is tinkering, testing, building and making. Here, only materials that are solid and durable prevail. Well-made, easy to maintain and easy to repair. Just like HIMACS.



Photographed by Oschato - Visuelle Medien experimenta - gGmbH

Living Spaces

Any materials used within your home should be selected with utmost care as you will be using them for many years. The 15-year warranty with a Quality Club fabricator ensures that your satisfaction is guaranteed.

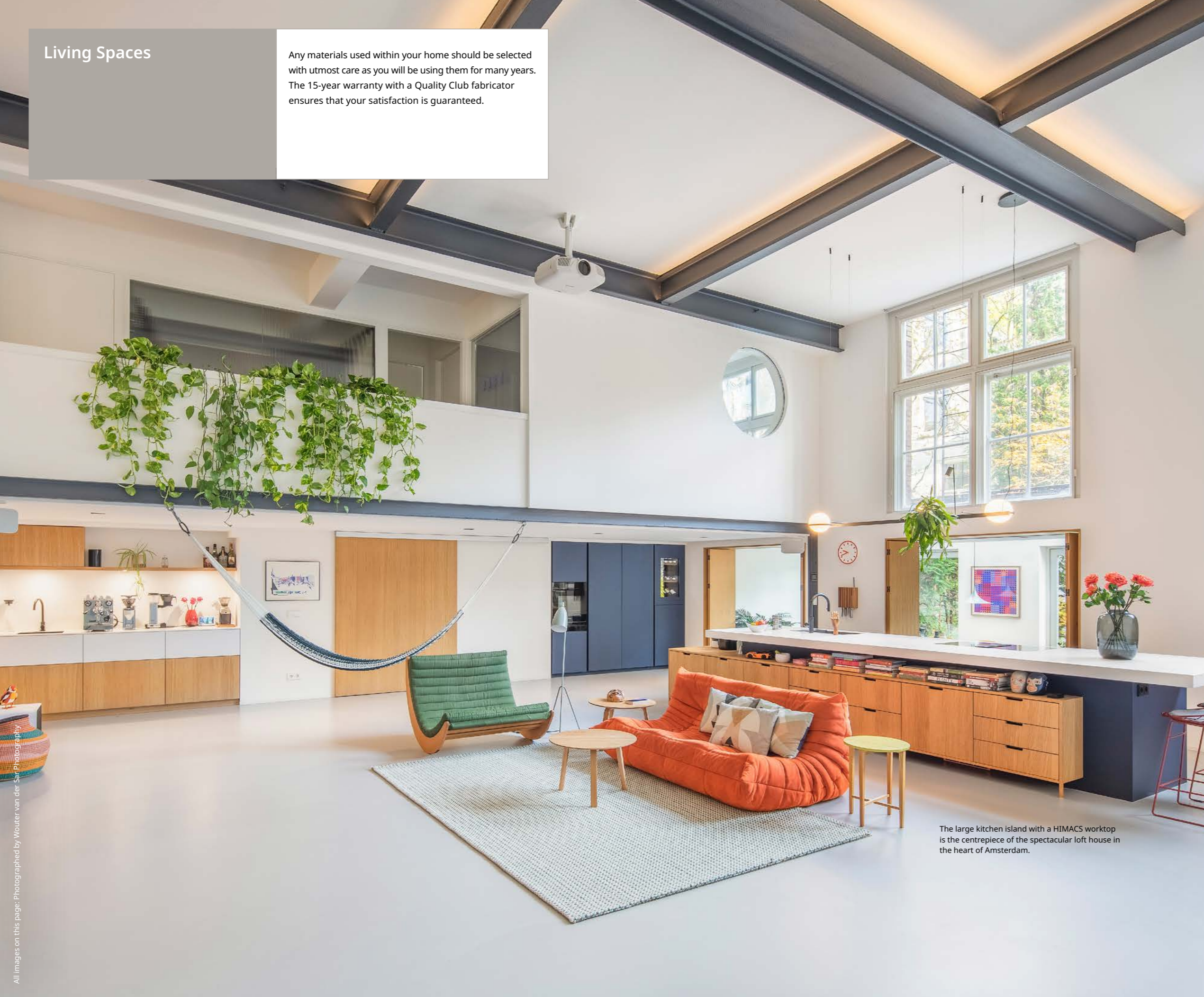

The large kitchen island with a HIMACS worktop is the centrepiece of the spectacular loft house in the heart of Amsterdam.

Kerkstraat Loft

Location: Amsterdam, The Netherlands
Design: Standard Studio, The Netherlands, standardstudio.nl
Fabrication: Brandsing Meubelmakers, The Netherlands, brandsing.nl
HIMACS Supplier: Baars & Bloemhoff
Material: HIMACS Alpine White

Formerly a ballet school, today a spacious loft house. The kitchen area of the loft has been designed to focus on socialising. The exceptionally large kitchen island with the HIMACS worktop in Alpine White forms the focal point of this flat. It combines the robustness of the characteristic loft style with the casualness of a warm and appealing communication centre. And of course, the practical and hygienic features of HIMACS are not to be missed, which the young family and their active lifestyle demand.



Kitchen

The ingredients, as well as the material on which they are prepared, have a key role in creating a high-quality meal. HIMACS is a non-porous, dirt-repellent and hygienic surface, and combined with its Thermalcure-technology, results in the best surface-quality for working with food and everyday household chemicals.



Photographed by Andreas Laabs

Private Kitchen

Location: Berlin, Germany

Design: Anna Nibell, Germany, studioanna.de

Fabrication: GRAICHEN Bau- und Möbelwerkstätten, Germany, graichen-gmbh.eu

HIMACS Supplier: Klöpfer Surfaces

Material: HIMACS Intense Ultra Dark Grey

If you want a really dark kitchen, you need materials that work in a kitchen as well.

Traditionally, the kitchen is where the highest standards of good design and functionality meet. This design by a Berlin-based architect is radical in every respect. The functional furniture in deep dark grey is elegant, compact and leaves nothing to be desired in terms of function. Seamless integrated sink, food-safe surface, easy to clean, pleasant to the touch. Ultra-dark. Cool. Perfect.

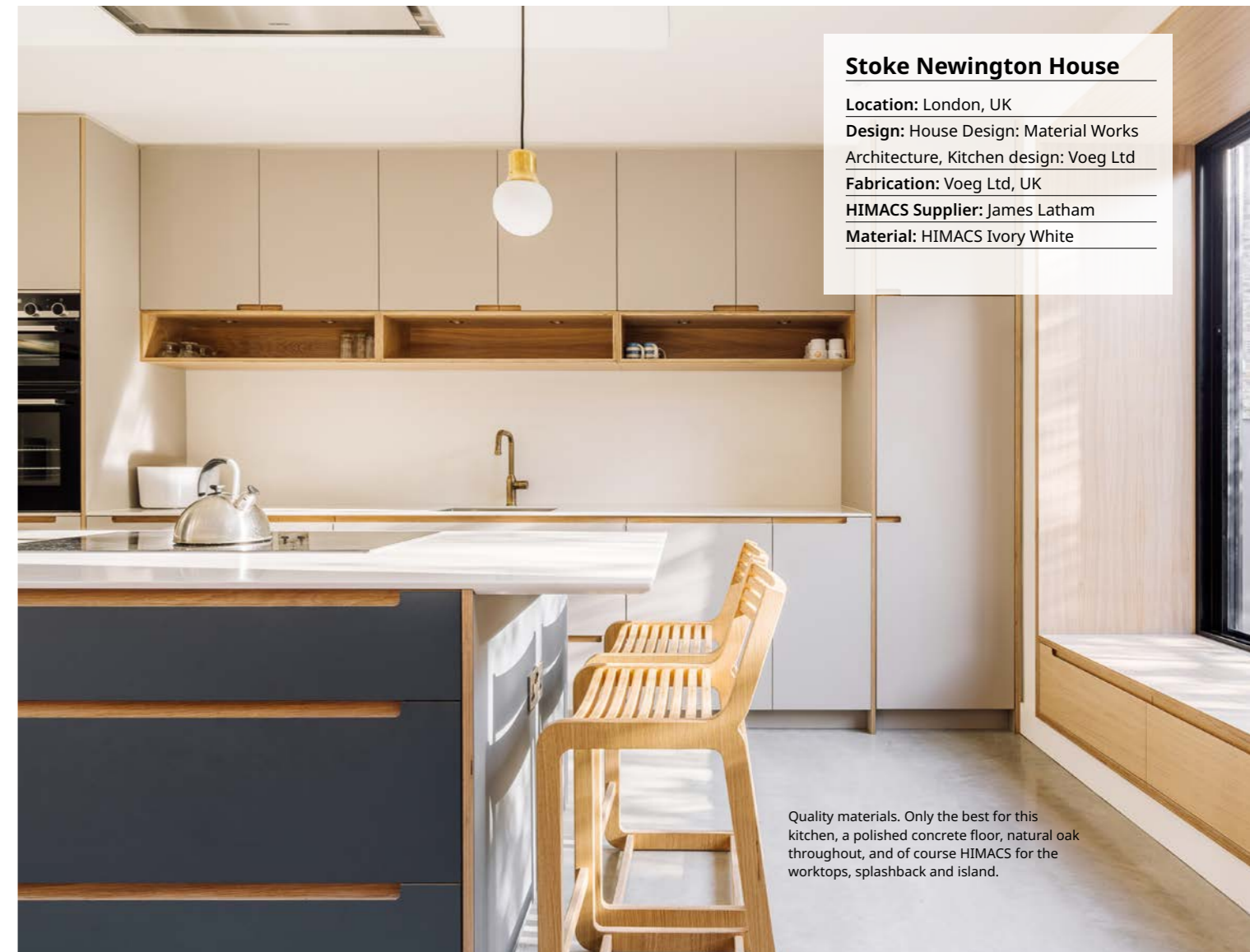

Stoke Newington House

Location: London, UK

Design: House Design: Material Works Architecture, Kitchen design: Voeg Ltd

Fabrication: Voeg Ltd, UK

HIMACS Supplier: James Latham

Material: HIMACS Ivory White

Quality materials. Only the best for this kitchen, a polished concrete floor, natural oak throughout, and of course HIMACS for the worktops, splashback and island.

Here old and new begin a wonderful friendship

Furnishing historical buildings is a challenge. And a great pleasure when the task is successful. This is the case here: the converted historic sandstone building was to be upgraded with a modern look and up to date technology. The HIMACS installation in the kitchen does just that. The remarkable wall cladding gives the kitchen its modern appearance whilst being extremely easy to maintain. The solid kitchen island and the worktop have no visible joins, and so are totally hygienic with nowhere for germs and dirt to hide. And cleaning is simple - just a damp cloth and mild cleaning agent.

Private Kitchen

Location: Ostuni, Italy

Design and Fabrication: Pirkelmann + Schmidt, Germany, pirkelmann-schmidt.de

HIMACS Supplier: Klöpfer Surfaces

Material: HIMACS Alpine White



Photographed by Pirkelmann + Schmidt



Modern kitchen extension

This kitchen extension focuses on the warm radiance of high-quality natural tones. The contemporary handle-less kitchen units are complemented by the Ivory White HIMACS worktops, chosen as much for their ease of cleaning as their sleek, attractive finish. HIMACS is the perfect material for kitchen worktops as it is non-porous, extremely easy to clean with just a wipe of a damp cloth and can be seamlessly joined meaning there are no cracks for dirt and germs to linger.



All images on this page: Photographed by Gautier Houba

Private Kitchen

Location: Nieuwe Wetering, The Netherlands

Design and Fabrication: Design & Meer, The Netherlands, design-en-meer.nl, Studio Doorbakken

HIMACS Supplier: Baars & Bloemhoff

Material: HIMACS Alpine White

Mix and Match is a HIMACS speciality!

Massive wooden beams, grey floor tiles, high-gloss aqua-coloured wall tiles and HIMACS Alpine White. This huge light-filled kitchen mixes all the materials in a harmonious blend, with HIMACS contributing its hygienic, easy to clean properties whilst adding design features to the converted farmhouse.

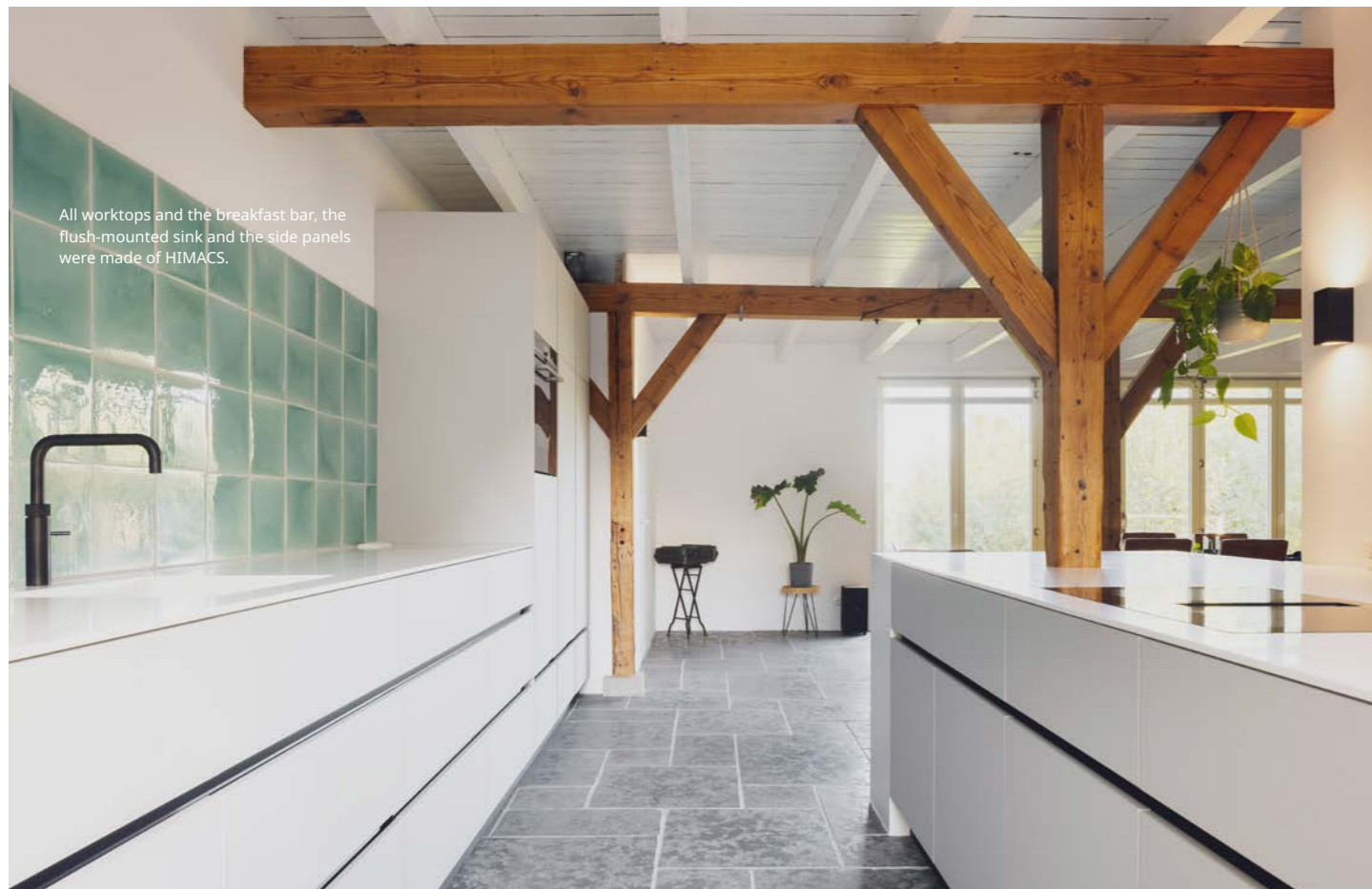

Kitchen Envol

Location: Fuveau, France

Design: Charlotte Raynaud Hegenbart, France

Fabrication: Menuiserie Hegenbart, France, hegenbart.fr

HIMACS Supplier: Mobistrat

Material: HIMACS Ispani, Peanut Butter

Because a kitchen doesn't have to look like a kitchen.

The central element of this high-quality and creative kitchen is the cooking island: the worktop, which extends across the width and partially down the sides, accommodates the sink, hob and a handy hidden spice storage area, and is the communicative focal point of the room. The base of the island tapers towards the bottom, conveying a feeling of lightness. The spectacular colour mix of the two HIMACS shades Ispani and Peanut Butter is set off by the brass inlay to dramatic effect.



The high-precision workmanship of HIMACS allows this spice rack to be electrically recessed into the worktop.



Bathroom

Thanks to its waterproof surface and the extensive range of high-quality washbasins, HIMACS is becoming increasingly popular in the bathroom. The warm, pleasing feel of the material, coupled with its ease of care means HIMACS is simply perfect.

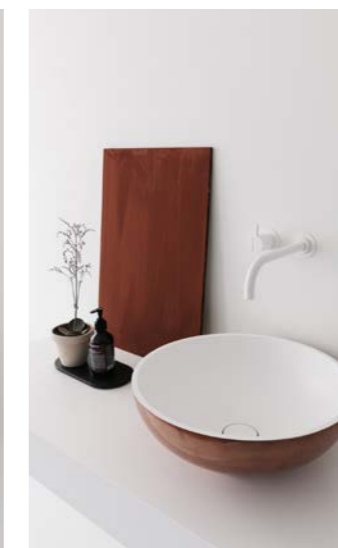

Noon copper finish

Design: Marike Andeweg, Not Only White, The Netherlands, notonlywhite.com

Fabrication: Rosskopf + Partner AG, Germany, rosskopf-partner.com

Material: HIMACS Alpine White

The long-standing creative partnership between Not Only White and HIMACS has produced a spectacular new design object: the new Noon model is the smallest round basin in the collection and is characterised by its innovative copper coating. Synergy 3D technology applies the wafer-thin copper-coloured coating via 3D printing.

Defra Furniture collection

Location: Milicz, Poland

Design: Internal studio project

Fabrication: Biuro Styl, Poland, biuro-styl.pl

HIMACS Supplier: Patron-Bis

Material: HIMACS Gemini, Sanremo

A dressing table is an almost intimate piece of furniture. A discreet, noble look, a pleasant feel and perfect hygiene properties are of particular importance. The Gemini Sanremo shade is reminiscent of antique furniture surfaces, whilst still providing that all important functional use.



Washstand Showroom

Location: Hamburg, Germany

Design: FLAGSTONE Hamburg, Germany, flagstone-hamburg.de

Fabrication: Markmann & Sabban Objekteinrichtung, Germany, markmann-sabban.de

HIMACS Supplier: Klöpfer Surfaces

Material: HIMACS Alpine White



The straightforward design of this washbasin has got what it takes. Sometimes a single piece of furniture changes the effect of a room. The proportions of this washbasin lend elegance and drama to the room. The front and rear edges of the washbasin serve as a rail for the multifunctional tray made of maple. The drain is cleverly concealed by an elongated cover, which is also easy to remove for cleaning.



Public restroom

Location: Lübeck, Germany

Design: Heske Hochgürtel Lohse | Architekten Part GmbH, Germany, heske-hochguertel-lohse-architekten.de

Fabrication: Krumbeck & Staercker, Germany, krumbeck-staercker.de

HIMACS Supplier: Klöpfer Surfaces

Material: HIMACS Star Queen

The side panels, washbasins and countertop washbasins of this public sanitary facility are all made of HIMACS. The result: a place with a solid appearance and easy maintenance, with hygienic properties all made possible with HIMACS.

Airport

Desks, counters and shelving at airports are exposed to extremely heavy and constant use. It is here that the properties of HIMACS come into their own – easy to clean and extremely robust, thanks to its innovative Thermalcure-technology.

Marine Industry

A new composition of HIMACS from the Hightech laboratories of LX Hausys has been developed for use in shipbuilding. HIMACS FR, has been awarded the IMO certificate module B and D in compliance with the Marine Equipment Directive for its fire resistant and fire-retardant properties.

All images on this page: © Deutsche Lufthansa AG, Photographer: Christian Laikemper



Milan Airport Lufthansa Lounge

Location: Milan, Italy
Design: Kitzig Interior Design GmbH, Bochum, kitzig.com
Fabrication: Baierl&Demmelhuber Innenausbau GmbH, Töging, Germany
Material: HIMACS, Alpine White, Lunar Sand

Its durability and ease of care mean that HIMACS always creates a good first impression.

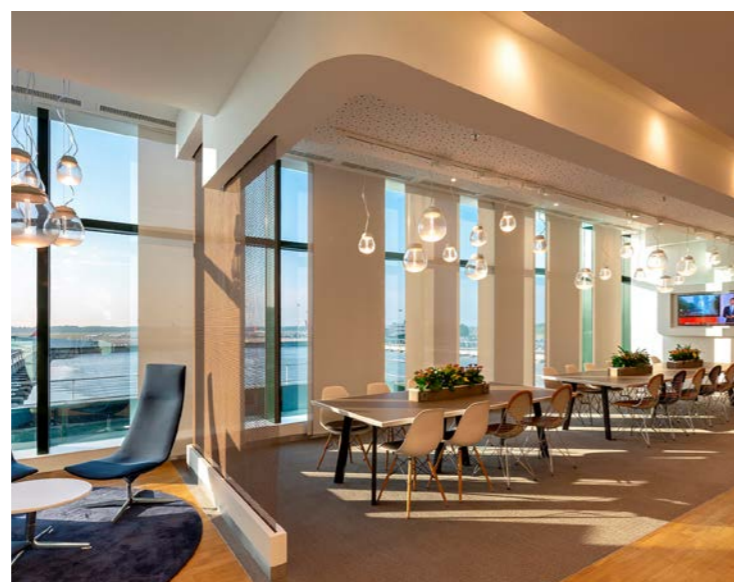

Quality and style are evident in the perfect detailing

Lufthansa works with HIMACS. The German airline relies on the elegance and functionality of the material at Frankfurt Airport and also more recently at Milan's Malpensa Airport. The reception desks, library shelves, all standing tables, zone partitions attached to the ceiling and the catering units are all made of HIMACS.



HIMACS is certified by the International Maritime Organization (IMO) according to MED (Marine Equipment Directive) modules B and D, which confirms the suitability of the solid surface material for use at sea.

All images on this page: Photographed by Studio Borlenghi

Yacht EVO V8

Location: Italy
Design: Shipyard: Blu Emme Yachts S.R.L. Italy, evoyachts.com
Material: HIMACS Alpine White

The indoor-outdoor lounge on the high seas The EVO-V8 is the new flagship of the Italian yacht manufacturer Blu Emme Yachts. Impressive in every respect, the lounge area is positioned between the indoor and outdoor areas. By opening the huge sliding windows, the area seems to merge indoors and outdoors. The corner bar has a sink embedded in the work surface which is made of HIMACS: its versatility and special properties make HIMACS the ideal material for shipbuilding projects.



Best of the Last Decade

In recent years HIMACS has been specified more and more by architects and designers – only the best quality can convince demanding clientele like these. Thanks to their ability and talent and to the superior quality of material and fabrication some masterpieces have been achieved with HIMACS. Although not necessarily recent, they still inspire users and owners. A selection can be found here.



Händel House

Location: Halle, Germany

Design: Gerhards & Glücker, Germany, gerhardsgluecker.com

Fabrication: Möbel Damm, moebel-damm.de

Material: HIMACS Arctic White

Baroque forms to honour a baroque musician

This building to honour the great musician Georg Friedrich Händel transitions from an understated exhibition and reception area to an opulent Baroque hall. HIMACS links and enables both: the ornamental splendour as well as the subtle play of lights.

Hotel Puerta America

Location: Madrid, Spain

Design: from left to right: Christian Liaigre, France, christian-liaigre.fr – Ron Arad, UK, ronarad.co.uk – Zaha Hadid Architects, UK, zaha-hadid.com

Material: HIMACS Alpine White, Black, Fiery Red

19 well-known architects and designers designed this hotel – naturally using HIMACS

The result of their work is simply breathtaking, with every room being a veritable stand-alone masterpiece. HIMACS was with them every step of the way – inspiring the designers to create their most daring designs.



Atlas Swimming Pool

Location: Paris, France

Design: Yoonseux Architectes, France, yoonseux.com

Fabrication: ASKA Interior, France, aska-interior.com

Material: HIMACS Arctic White

Water and HIMACS do mix

This indoor swimming pool in a Parisian school was designed mainly with HIMACS: parts of the exterior walls, the geometrical relief on the interior walls, the non-slip floor in the shower area and many individual items of furniture were all created in HIMACS Arctic White. Its perfect hygiene and ultra-flexible form are important properties of the material, which also gives the space a unique atmosphere.

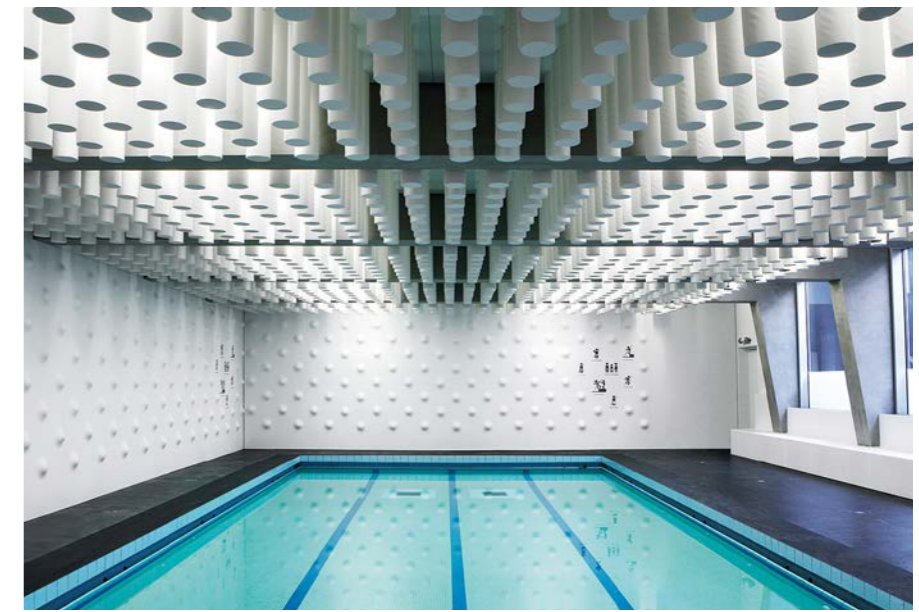

Raiffeisen Bank Zürich

Location: Zurich, Switzerland

Design: NAU Architecture, Switzerland, Drexler Guinand Jauslin Architekten, Switzerland, nau.coop, dgj.ch

Fabrication: Wallcovering patterns design: ROK, Rippmann Oesterle Knauss, Switzerland, rok-office.com – Wallcovering and joinery: Glaeser Baden, Switzerland, glaeser.ch

Material: HIMACS Alpine White

HIMACS helps create a personal vision

The Raiffeisen Bank in Zurich displays the portraits of former prominent residents that stand out thanks to the intricate cutting of triangles of different sizes and the spartan overall interior architectural design.

Sokcho House in White

Location: Inheung-ri, Toseong-myeon, Goseong-gun, Gangwon-do, South Korea

Design: Woo-jin, LIM AEV Architectures, aev-architectures.com

Material: HIMACS Alpine White

The house that plays with light

HIMACS has a sensuous way of dealing with light: When used as a facade the material provides great aesthetic properties. The light is absorbed or reflected, depending upon the intensity and angle of incidence, and gives the Sokcho Housing in Alpine White a mystical feel.



We have a strong partner network for your most creative ideas.

Architects and designers have awe-inspiring ideas. And exceptional craftsmen transform them into reality using HIMACS.

Contact us to find our network of exclusive distributors serving more than 5,000 fabricators across Europe and our numerous Quality Club Training Centres. This is our strategy to guarantee the best quality at all levels.

We can also offer you the security of our global LX Hausys After-sales Service with our experienced HIMACS experts all around the world.

All contact details of our network can be found at

himacs.eu
Because Quality Wins.



PRODUCT SPECIFICATION

The perfect basis for your ideas: our comprehensive range of sheets.

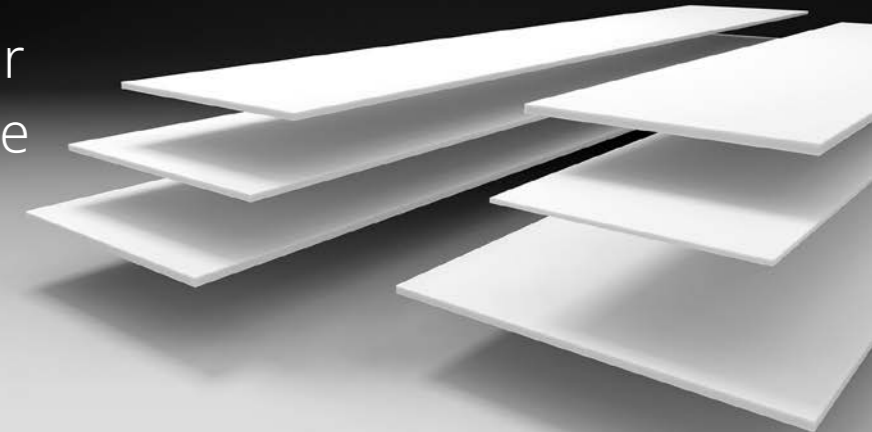

Sheet Material

- HIMACS is available in different thicknesses, formats and sizes. Perfect for maximum cutting and minimal costs. However, not all colours are available in every thickness. See the table for availability below.
- HIMACS sheet material is available in thicknesses of 4.5 mm, 6 mm, 9 mm, 12 mm and 20 mm as well as the corresponding sheet formats.

HIMACS is also available in special formulations:

- **HIMACS Exteria®:** HIMACS FR – Low flammability, ETA Certified, IMO Certified, Norm EN 45 545 Class R1 HZL3 for fire protection on railway vehicles. HIMACS UV+ – Advanced UV resistance.
 - **HIMACS Ultra-Thermoforming:** Advanced Thermoforming, up to 6 mm internal radius.
 - **HIMACS Intense-Ultra:** The best of two worlds – Ultra-Thermoforming and Intense Colour Tecnology
- For more information, see page 69.

Dimensions – Sheet material

Standard Format

Standard formats are available on stock, for specific thicknesses per colour, please refer to the colour chart on page 66, or contact your sales representative.

| SHEET THICKNESS IN MM | SHEET WIDTH IN MM | SHEET LENGTH IN MM |
|-----------------------|-------------------|--------------------|
| 4.5 | 930 | 3000 * |
| | 760 | 2490 |
| 6 | 910 | 2490 * |
| | 1350 | 3680 * |
| 9 | 760 | 3680 |
| | 910 | 3680 * |
| | 1350 | 3680 * |
| 12 | 760 | 3680 |
| | 910 | 3680 * |
| | 1350 | 3000 *** |
| | 1350 | 3680 * |
| 20 | 1520 | 3680 * |
| | 760 | 3000 |

Ultra-Thermoforming Format

| SHEET THICKNESS IN MM | SHEET WIDTH IN MM | SHEET LENGTH IN MM |
|-----------------------|-------------------|--------------------|
| 12 | 760 | 3680 ** |
| | 930 | |
| | 1520 | |

- * Only available in S028 Alpine White.
- ** Only available in S928 Alpine White.
- *** Only available in Opal

Standard Formats

760 x 2490 mm

910 x 2490 mm

760 x 3000 mm

1350 x 3000 mm

760 x 3680 mm

910 x 3680 mm

930 x 3680 mm

1350 x 3680 mm

1520 x 3680 mm

Chemical and Technical Information

Over 20 years research and development by LX Hausys engineers, means that we are producing high-tech quality products.

Thanks to the new Thermalcure-technology, developed by LX Hausys, HIMACS performs better than the standard in Solid Surface.

For example you save precious time because it is easier to sand.

And thanks to the Thermalcure-technology used during production, HIMACS has excellent heat-resistance.

Chemical resistance

HIMACS is a fully homogenous material with no pores and is thus simple and easy to clean.

| CLASS | STAINING AGENT | APPLICATION TIME | EVALUATION OF G002 CHANGES | EVALUATION OF S028 CHANGES |
|--|--|------------------|----------------------------|----------------------------|
| GROUP 1 | Water | 16h – 24h | 5 to 4 | 5 to 4 |
| | Toothpaste | | | |
| | Hand cream | | | |
| | Natural fruit and vegetable juice | | | |
| | Lemonade and fruit drinks | | | |
| | Meats and sausages | | | |
| | Animal and vegetable fats and oils | | | |
| | Yeast suspension in water | | | |
| | Salt (NaCl) solutions | | | |
| | Mustard | | | |
| | Lyes, soap solutions | | | |
| | Cleaning solution | | | |
| | Alcoholic beverages | | | |
| | Phenol and chloramine-T disinfectants | | | |
| Citric acid (10% solution) | | | | |
| GROUP 2 | Coffee (120gr coffee per ltr. water) | 16h | 5 | 4 to 5 |
| | Black tea (9gr tea per ltr. water) | | | |
| | Milk (all types) | | | |
| | Cola beverages | | | |
| | Wine vinegar | | | |
| | Alkaline-based cleaning agents (10% in water) | | | |
| | Hydrogen peroxide (3% solution) | | | |
| | Ammonia (10% solution of commercial concentrate) | | | |
| | Lipstick | | | |
| | Water colours | | | |
| Laundry marking inks | | | | |
| Ball point inks | | | | |
| GROUP 3 | Sodium hydroxide (25% solution) | 10min. | 5 to 4 | 4 to 5 |
| | Hydrogen peroxide (30% solution) | | | |
| | Acetone | | | |
| | Trichlorothane | | | |
| | Other organic solvents | | | |
| | Concentrated vinegar (30% acetic acid) | | | |
| | Bleaching agents and sanitary cleaners containing them | | | |
| | Hydrochloric acid based cleaning agents | | | |
| | Tincture of iodine | | | |
| | Boric acid | | | |
| | Lacquers and adhesives (except fast-curing materials) | | | |
| | Amidosulfonic acid descaling agents (≤10% solution) | | | |
| | Nail varnish | | | |
| | Nail varnish remover | | | |
| Stain or paint remover based on organic solvents | | | | |
| GROUP 4 | Acetic acid (5% solution) | 20min. | 5 | 4 |

Tests carried out in accordance to EN ISO 19712 for Solid Surface material, please see table (left) for results.



Evaluation

| RATING LEVEL | DESCRIPTION |
|--------------|--|
| Rating 5 | No visible change |
| Rating 4 | Slight change in gloss and/or colour, only visible at certain viewing angles |
| Rating 3 | Moderate change in gloss and/or colour |
| Rating 2 | Marked change in gloss and/or colour |
| Rating 1 | Surface distortion and/or blistering |

a = Acids and alkalis, in concentrations stronger than those shown in group 3, which can be contained in commercial cleaning agents, can cause surface damage or marking, even with very short contact times. Any spillage of such materials should be washed off immediately.

Technical data sheet

HIMACS is extremely resistant to dirt and wear and tear, so that you can enjoy many years' peace of mind with the outstanding quality of your new product.

| SPECIFICATION | UNIT | RESULT SOLIDS | RESULT GRANITE | TEST METHODS |
|---|------------------------|---|-----------------------|--|
| Flexural-E-modulus | MPa | 8900 | 7730 | DIN EN ISO 178 |
| Flexural strength | MPa | 70.1 | 64.3 | ASTM D638 |
| Breaking elongation | % | 1 | 1.1 | DIN EN ISO 178 |
| Tensile strength | MPa | 69.5 | 56.3 | DIN EN ISO 527 |
| Density | g/cm3 kg/m3 | 1.75 1750 | 1.65 1650 | ISO 1183 ISO 1183 |
| Ball indentation hardness | N/mm2 | 257 | 239 | DIN EN ISO 2039-1 |
| Mohs hardness | | 2 to 3 | 2 to 3 | EN 101 |
| Pencil hardness | | >9H | >9H | ISO 15184 |
| Water absorption weight strength/thickness | | <0,1% <0,1% | <0,1% <0,1% | DIN EN 438 Part 12 |
| Impact resistance impactor drop ball test (fall height) | N mm | ≥25 ≥1500 | ≥25 ≥1500 | E DIN EN 438, 02/02 Part 2/20 E DIN EN 438, 02/02 Part 2/21 |
| Slip resistance | | >0,32 – 0,9 | | GMG100 (replaces R9) |
| Slip resistance | | angle of acceptance of more than 10° to 19° = R10 | | DIN 51130 |
| Climate change resistance | °C | ≥0,05 | ≥0,05 | AMK |
| Dry heat (pan base) | °C | ≥100 (7C) | | DIN 68 861, Part 7, 04-85 |
| Damp heat (pan base) | °C | ≥100 (7C) | | DIN 68 861, Part 8, 04-85 |
| Temperature change resistance | °C | no change | | UNI 9429 |
| Resistance to cigarette burns | | 6C | 6B | DIN 68 861, Part 6, 11-82 |
| Scratch resistance | | 4D | 4B | DIN 68 861, Part 4, 11-81 |
| Electrostatics Conductivity | 1 x 10 ¹² Ω | insulating non-conductive | | DIN IEC 1340-4-1, 04-92 EN 61340-5-1 |
| Thermal conductivity | W/mK | 0.636 | 0.55 | DIN EN 12664 |
| Thermal resistance | m2K/W | 0.038 | 0.045 | DIN EN 12664 |
| Thermal Expansion Coefficient for Standard HIMACS Products | mm/mK m/m/°C | 0.045 45 x 10-6 | 0.055 | DIN EN 14581 |
| Water vapor transmission properties – diffusion resistance factor | μ | 18607 | 16150 | DIN EN ISO 12572 |
| Dimensional change by change in relative humidity length thickness mass | % % % | -0.03 0.06 0.05 | -0.02 0.03 0.05 | DIN EN 318, edit. 5, 1998 |
| Resistance to boiling water increase in weight increase in thickness | % % | <0,1 <0,1 | >0,1 <0,1 | E DIN EN 438, 02/02 Part 2/12 |
| Light fastness (Xenon) | scale 0 – 10 | better than 6 | better than 6 | DIN 53 387, 04-89 |
| Food tolerance | S028 | suitable for all colours | | LMBG S 31 |
| Hygiene | | suitable | suitable | LGA Hygiene Certificate |

HIMACS Fire Classification

| MATERIAL CATEGORY | MATERIAL THICKNESS | PRODUCT TESTED | TEST METHOD | RESULT |
|-----------------------------|-------------------------------|---|---------------------|---------------------------------------|
| HIMACS Standard range | 12 mm | HIMACS colour range*, M551, G554, Q001, Z005. | DIN 4102 | B1 |
| | | S028 | DIN 4102 | B1 |
| | | S028 | DIN 5510 | passed (S4 / SR2 / ST2 and FED30 < 1) |
| | | S028, T017, VW01, W001 | NF P92-501 | M1 |
| | HIMACS colour range* | EN 13501-1 | B – s1 – d0 | |
| HIMACS Standard range | 20 mm | S028 | EN 13501-1 | B – s1 – d0 |
| | 12 mm plus fibre cement board | HIMACS colour range* | EN 13501-1 | B – s1 – d0 |
| HIMACS Special Formulations | 12 mm | S728 CE MED | DIN 4102 | B1 |
| | | S728 CE MED | EN 13501-1 / SBI | B – s1 – d0 |
| | | S728 CE MED | EN 45545 | passed R1/HZ3 |
| | | *IMO S728 CE MED + IMO colour range in Solids | Module B & Module D | IMO certified |
| | | S928 Ultra-Thermoforming | DIN 4102 | B1 |
| HIMACS Special Formulations | 12 mm | S928 Ultra-Thermoforming | EN 13501-1 | B – s1 – d0 |
| | | S922U Intense Ultra | DIN 4102 | B1 |
| | | S728 HIMACS-FR | DIBT | ETA |
| HIMACS Exteria® | 12 mm | S728 HIMACS-FR, S828 HIMACS-UV+ | NF P92-501 | M1 |

* For details of HIMACS colour range please contact your sales representative or refer to our reports: 2019-2213, 167467, 347196, MED233220CS, 210646-K1.

COLOURS

Colours are key in design. Elegant Alpine White, warm Babylon Beige or mystical Cima. We have virtually any colour you could wish for. No matter what colour you choose, HIMACS remains 100% homogeneous.

Extra service on demand

If needed, LX Hausys Europe can produce different dimensions and bespoke colours. To learn more about the conditions, please contact us at himacs.eu



Terrazzo

The coarse-grained, 'splattered' look of these two colours radiates a perfect blend of longevity and elegance.

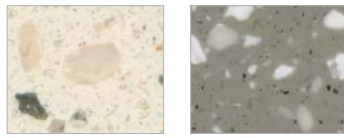

Terrazzo Classico Q001 [12 mm]
Terrazzo Grigio Q002 [12 mm]

Lucent

When combined with precisely positioned light sources, the translucent pastel shades become transformed into dramatic design "highlights".

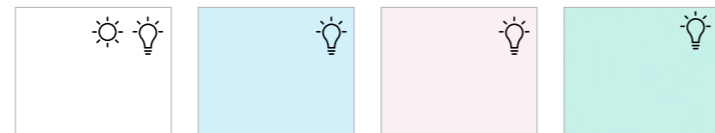

Opal S302 [12/6 mm] Δ E5
Sapphire S303 [12 mm]
Ruby S304 [12 mm]
Emerald S305 [12 mm]

Solids

From elegant to extravagant, classic to ultra-contemporary.



Alpine White S028 [20/12/9/6/4.5 mm] Δ E5
Diamond White S034 [12 mm] Δ E5
Arctic White S006 [12/9/6 mm]
Ivory White S029 [12/6 mm] Δ E5
Nougat Cream S201 [12/6 mm]
Satin White S001 [12/9/6 mm]
Cream S009 [12/6 mm] Δ E5
Almond S002 [12 mm] Δ E5



Babylon Beige S102 [12 mm]
Suede S121 [12 mm]
Grey S005 [12/9/6 mm]
Marta Grey S108 [12 mm]
Steel Grey S109 [12 mm]
Concrete Grey S103 [12 mm]
Banana S026 [12 mm]
Orange S027 [12 mm]



Fiery Red S025 [12 mm]
Light Green S212 [12 mm]
Sky Blue S203 [12 mm]
Midnight Grey S117 [12 mm]
Dark Night S111 [12 mm]
Coffee Brown S100 [12 mm]
Black S022 [12/9/6 mm]

20 mm: Colours indicated above are available on stock. Other colours are available on special request except for Chic Concrete, Shadow Concrete, Ebony Concrete and Marmo Collection. Minimum quantities order apply.



Marmo

Captivating random veined texture, reminiscent of marble.

NEW AURORA COLOURS



Aurora Torano M601 [12 mm]
Aurora Bisque M612 [12 mm]
Aurora Umber M614 [12 mm]
Aurora Blanc M617 [12 mm]
Aurora Cotton M615 [12 mm]



Pavia M603 [12 mm]
Aurora Bianco M606 [12 mm]
Aurora Grey M608 [12 mm]
Sanremo M605 [12 mm]



Ispani M428 [12 mm]
Edessa M501 [12 mm]
Bellizzi M427 [12 mm]
Terni M201 [12 mm]
Naples M904 [12 mm]

Lucia

Natural trendy colours characterised by linear-edged, midsize particles: three of these are designed by Dutch Star Designer, Marcel Wanders.

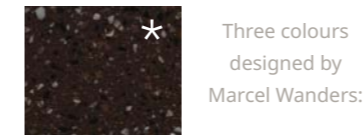

Red Quinoa W010 [12 mm]



Ice Queen W001 [20/12 mm]
Shadow Queen W003 [12 mm]
Star Queen W004 [12 mm]

Concrete

Warm tone, concrete-like finishes are now available in the solid surface material, providing completely new opportunities for architects and designers.

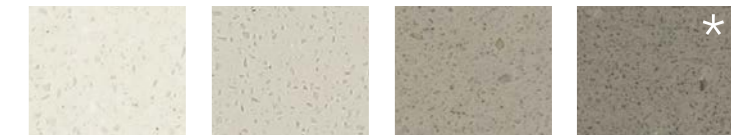

Snow Concrete G556 [12 mm]
Cloud Concrete G557 [12 mm]
Urban Concrete G554 [20/12/9/6 mm]
Steel Concrete G555 [12/9/6 mm]



Chic Concrete M551 [12 mm]
Shadow Concrete M552 [12 mm]
Ebony Concrete M553 [12 mm]

Volcanics

Full of depth and mysticism, akin to a precious natural stone but with all of the advantages of the Solid Surface Material.

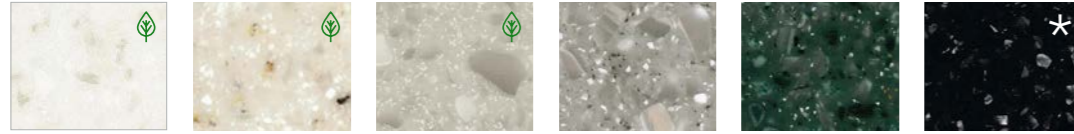

Gemini VW01 [12 mm] Minimum 14% Recycled Content
 Tambora VE01 [12 mm] Minimum 16% Recycled Content
 Santa Ana VA01 [12 mm] Minimum 13% Recycled Content
 Frosty VA22 [12 mm]
 Maui VG21 [12 mm]
 Cima VB02 [12 mm]

Granite, Quartz, Sand & Pearl

A huge selection of textures and colours. Natural, elegant and perfect in combination.



Cotton Field G180 [12 mm] Minimum 14% Recycled Content
 Windy Hill G181 [12 mm] Minimum 13% Recycled Content
 Highland G183 [12 mm] Minimum 12% Recycled Content
 Arctic Granite G034 [20/12/9/6 mm], Δ E5
 Lunar Sand G108 [12 mm]



White Quartz G004 [20/12/9/6 mm], Δ E5
 Tapioca Pearl G050 [12 mm]
 Crystal Beige G101 [12 mm]
 Pebble Pearl G107 [12 mm]
 Sea Oat Quartz G038 [12 mm] Δ E5
 Beach Sand G048 [12/9 mm] Δ E5
 Peanut Butter G100 [12 mm]
 Grey Sand G002 [12/6 mm] Δ E5

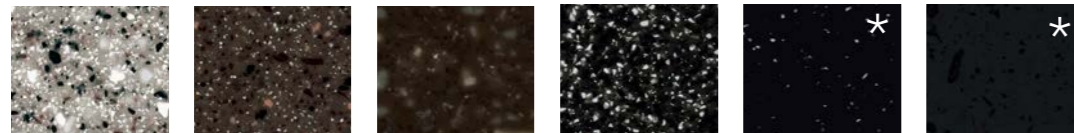

Platinum Granite G007 [12 mm]
 Allspice Quartz G063 [12 mm]
 Mocha Granite G074 [12 mm]
 Black Sand G009 [12 mm]
 Black Pearl G010 [12/6 mm]
 Black Granite G031 [12 mm]

Aster

With transparent grains and mother of pearl shimmer.



Nebula T010 [12 mm]
 Andromeda T017 [12 mm]
 Venus T011 [12 mm]

Strato

The Strato Collection enhances the HIMACS colour range with brand new design possibilities: the distinctive lines create geometry through its natural appearance and subtle look.



Stato Cloud Z001 [12 mm]
 Strato Wind Z003 [12 mm]
 Strato Slate Z005 [12 mm]

★ The basic HIMACS material is identical for every colour but it is important to note that darker and more heavily pigmented colours will show dust, scratches, haziness, marks left by hard water and other ordinary wear and tear more noticeably than lighter textured colours. Therefore colours marked with a ★ are less suitable for applications that are exposed to extensive surface contact such as worktops located in heavy traffic area.

☼ Some HIMACS colours are particularly suitable for outdoor applications because of their good UV-resistance. HIMACS offers a 10 Year Warranty on colours' UV resistance and loss of gloss over 40%, 10 Year Warranty on colour leaching and 20 Year Warranty on colour peeling, swelling or delaminating. The warranty is applicable after the first installation and is only valid for the sheet material; adhesives are excluded. The conditions for this warranty are based on practical experience and on-going tests.

≡ Marmo is a randomly veined product, specific fabrication guidelines need to be followed. Ask your sales partner for more information or visit himacs.eu.

☼ Lucent colours have a higher level of translucency, more evident when combined with light sources.

☼ Colours with this mark have a semi-translucent effect, evident when combined with light sources.

☼ Certified to contain pre-consumer recycled content.

☼ Design Collection by Marcel Wanders.

There may be deviations between the illustrated and actual colours owing to printing techniques. To receive the detailed colour range, please contact us at himacs.eu.

HIMACS ADVANCED SERIES

The HIMACS sheet range for special applications

The ability to use HIMACS in high-quality interior design is growing thanks to our wide range special application sheets. Projects with special tendering criteria and challenging design requirements can now be considered.

HIMACS-FR – Minimal flammability

The HIMACS-FR quality with reduced flammability is currently available in Alpine White S728 from the Solid Collection. HIMACS FR has the fire protection classification “B-s1-d0” according to EN 13501 (Single Burning Item test (SBI test))*.

Fixed in place with KEIL anchors and a BWM construction, the HIMACS façade in S728 – Alpine White successfully passed the ETA tests (European Technical Agreement).



Alpine White S728 [12 mm] Δ E5

HIMACS-UV+

HIMACS UV+ S828 (Alpine White) is the new exterior formulation offering better UV resistance, which is particularly important when the façade is exposed to high levels of sunlight. In addition the formulation achieved FR in M1 France. Furthermore, the unique properties of HIMACS S828 UV+ allow for the use of the highly effective UV-C disinfection method, frequently used in the healthcare sector.



Alpine White S828 [12 mm]

HIMACS Ultra-Thermoforming

HIMACS Ultra Thermoforming sheets are currently available in Alpine White S928 from the Solid Collection. For more information on the design possibilities of HIMACS Ultra Thermoforming products, see page 24.



Alpine White S928 [12 mm]

HIMACS Intense Ultra

The brand new HIMACS Intense Ultra is a revolution for the Solid Surface market which opens new possibilities for surface design. The aptly named Intense, which is a brand new material formulation, gives a powerful and remarkable performance. The product range combines the characteristics from two disparate worlds: Intense Colour Technology and Ultra-Thermoforming.



Intense Ultra Grey S923U [12 mm]



Intense Ultra Dark Grey S924U [12 mm]



Intense Ultra Black S922U [12/9/6 mm]

Sinks.
Spacious and elegant.



HIMACS Sinks for kitchen and healthcare applications

Spaciousness, durability and hygiene are all key quality features when choosing a sink for the kitchen or healthcare facility. The top quality models in the HIMACS range offer it all. These coordinated sinks are installed as undermounted creating extremely hygienic sink areas. Special custom-made creations are also an option.

[Click here and discover our complete product range on himacs.eu](#)

| | | | | | | | |
|----------------|---------------|---------------|----------------|--------------|--------------|--------------|---------------|
| <p>CS490R</p> | <p>CS490D</p> | <p>CS528R</p> | <p>CS400S</p> | <p>CS354</p> | <p>CS404</p> | <p>CS454</p> | <p>CS504</p> |
| <p>CS449RL</p> | <p>CS325R</p> | <p>CS325S</p> | <p>CS449RS</p> | <p>CS604</p> | <p>CS704</p> | <p>CS204</p> | <p>CS824D</p> |

· The HIMACS sinks CS824D, CS800D, CS490D are only available with overflow.
· All other HIMACS sinks are available with and without overflow.

H suitable for healthcare
K suitable for kitchen

Basins.
Best design for the bathroom.

Click here and discover our complete product range on himacs.eu

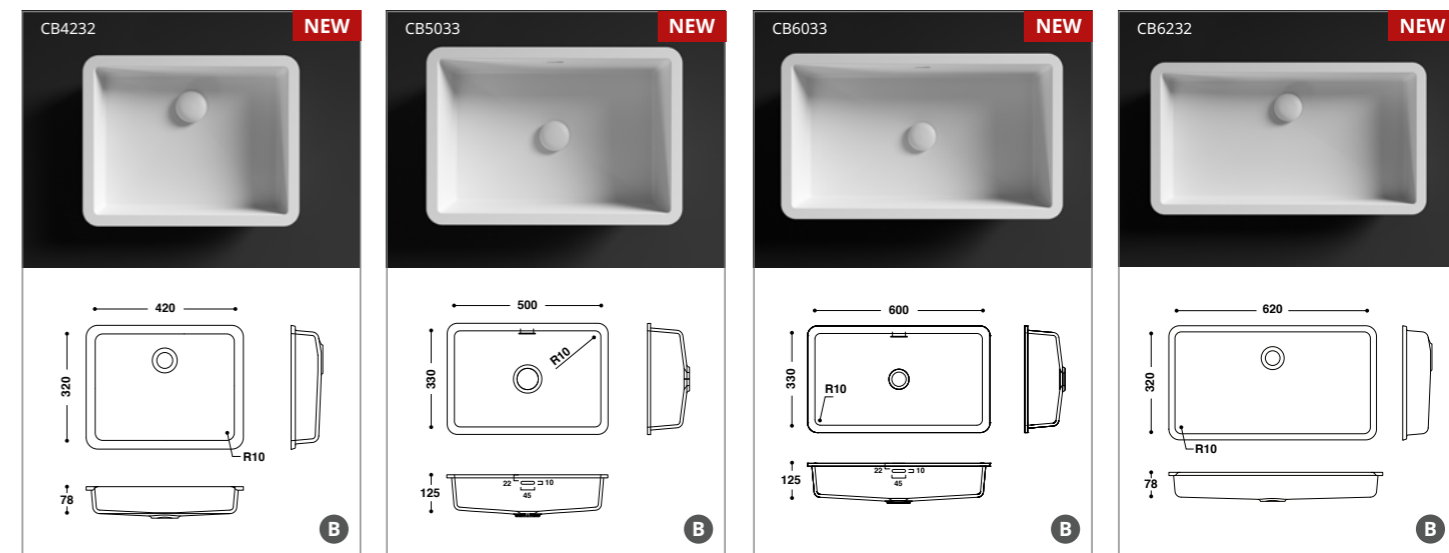

HIMACS Basins for the bathroom

Rectangular or oval, deep or shallow basins, small bathrooms or comprehensive solutions. The HIMACS range offers creative architects and bathroom planner's numerous options.

B suitable for bathroom

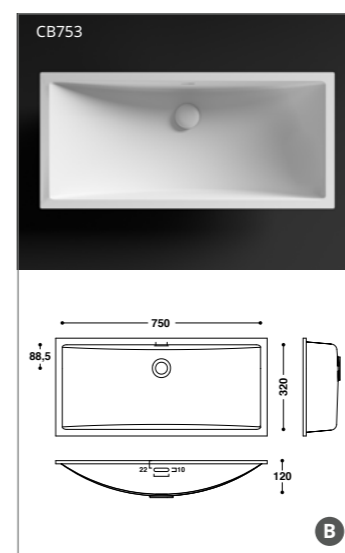
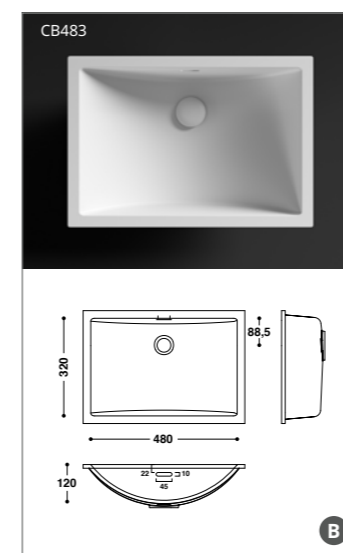
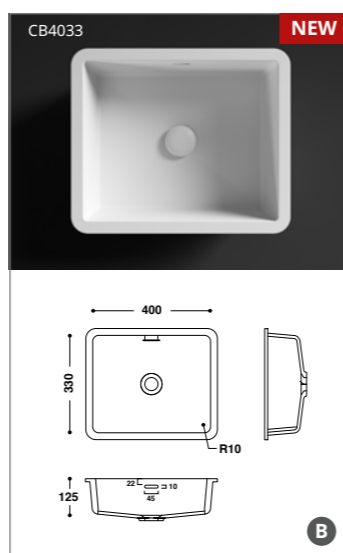
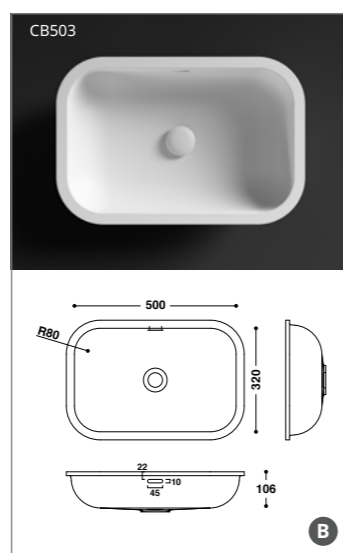
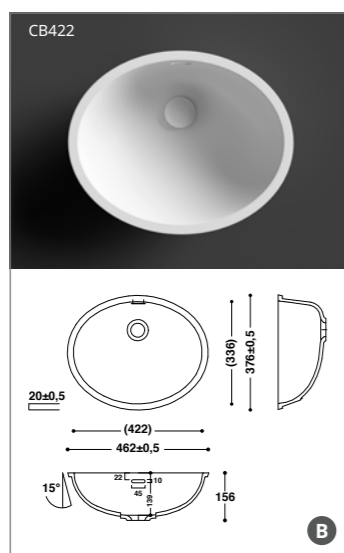
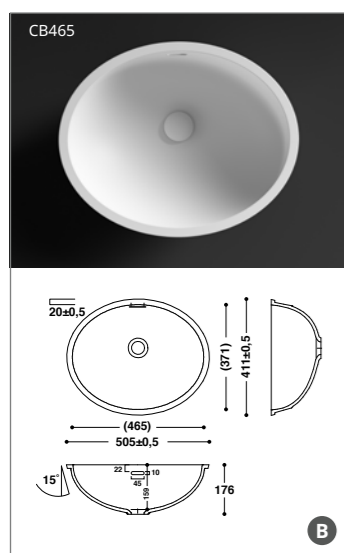
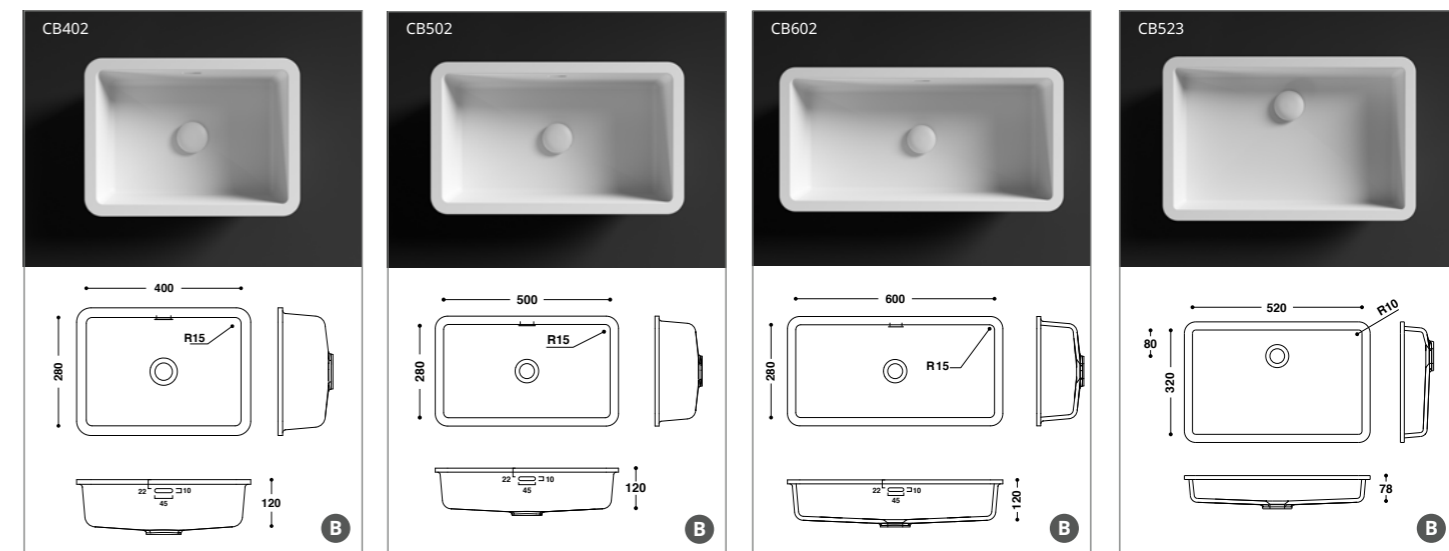
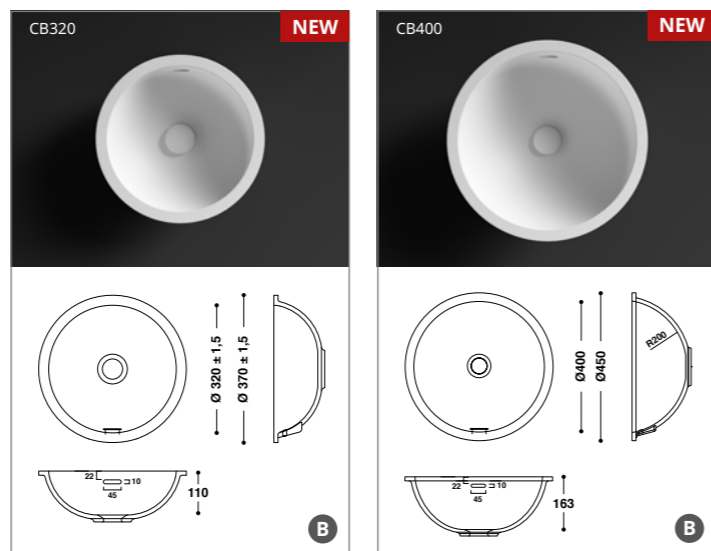

HIMACS Basins for the bathroom – Top mount installation

These basins are HIMACS answer to the trend for linear designs. All three basins were exclusively designed as top-mounted bowls. The narrow radius of the two rectangular models creates exceptionally spacious basins.

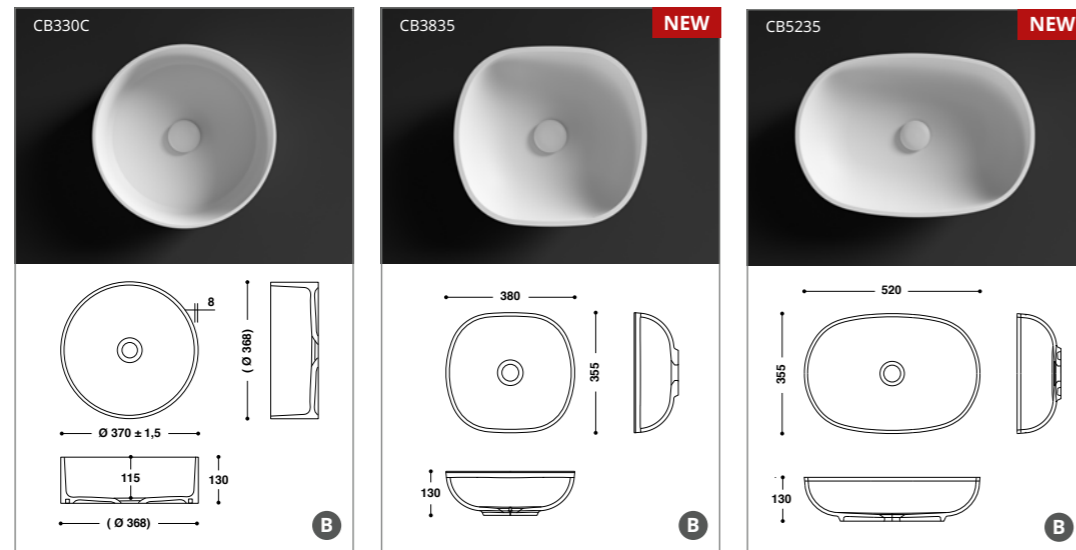
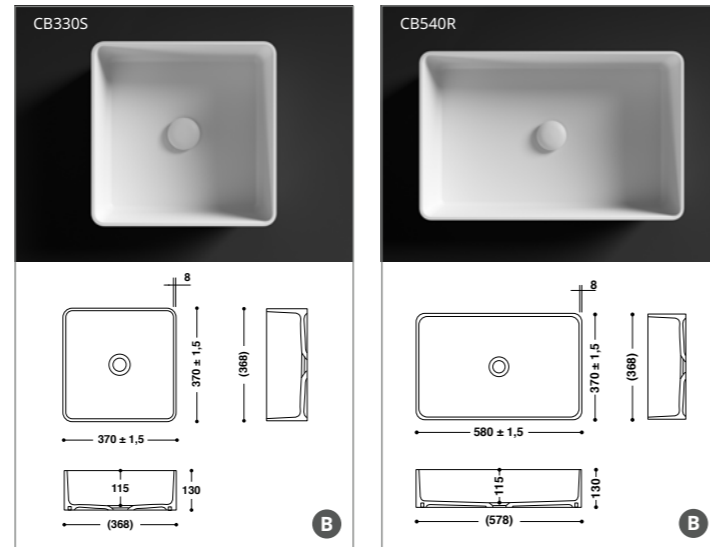

HIMACS Baby Bath

The neo-natal ward of a hospital is the one place where maximum hygiene, ergonomics and warmth are essential. The ergonomic shape of the bowl is specifically designed for babies.

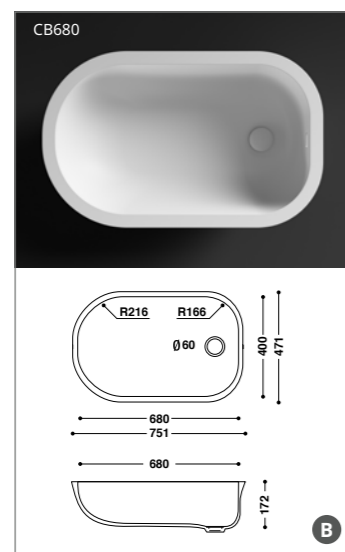

- The HIMACS basins CB523, CB4232, CB6232, the HIMACS Top Mounted Basins Collection and the HIMACS Baby Bath are only available without overflow.
- All other HIMACS basins are available with and without overflow.



Alpine White S028

HIMACS sinks, washbasins, Baby Bath, baths and shower trays are exclusively available in Alpine White S028.

Warranty: 15 years on all precast HIMACS basins, sinks, baby bath, baths and shower trays.

Bath and Shower Tray Collection.
Even more choices from HIMACS for a beautifully designed bathroom.



Click here and discover our complete product range on himacs.eu

HIMACS Shower Trays

HIMACS is the perfect material for bathrooms, with its warm, silky smooth feel. And the properties that make it so, also create a product which is incredibly easy to clean, and totally hygienic. The shower trays offer all of these advantages and more: three simple models extend the opportunities to bring the design and functional features of the bathroom to the forefront to design perfect wellness areas in homes, hotels and public spaces.

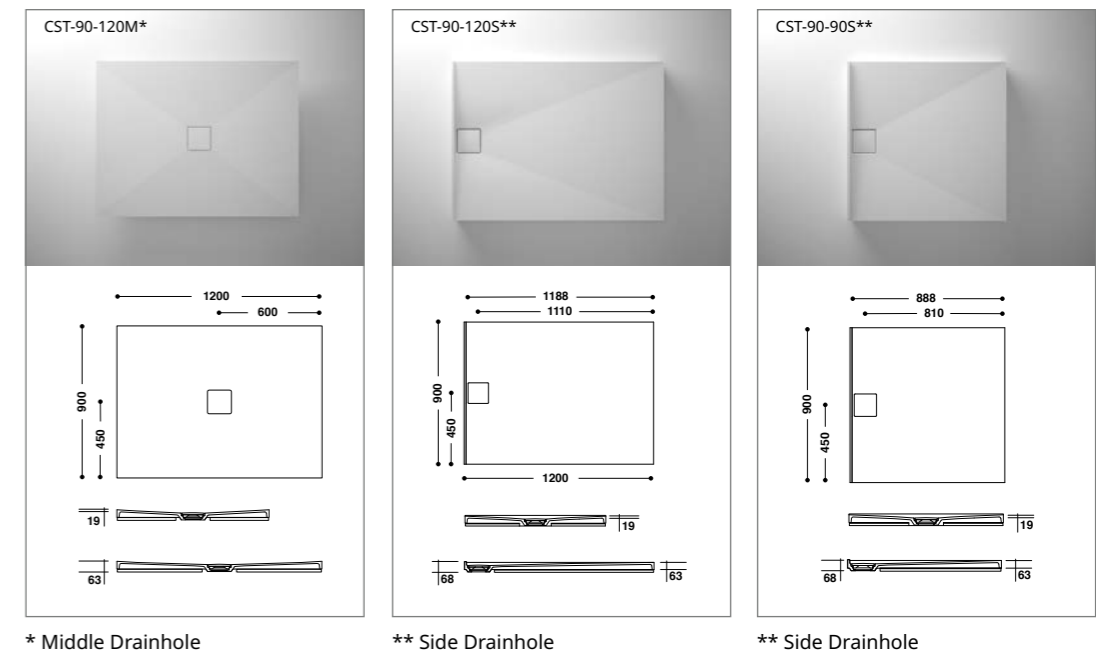

* Middle Drainhole ** Side Drainhole ** Side Drainhole

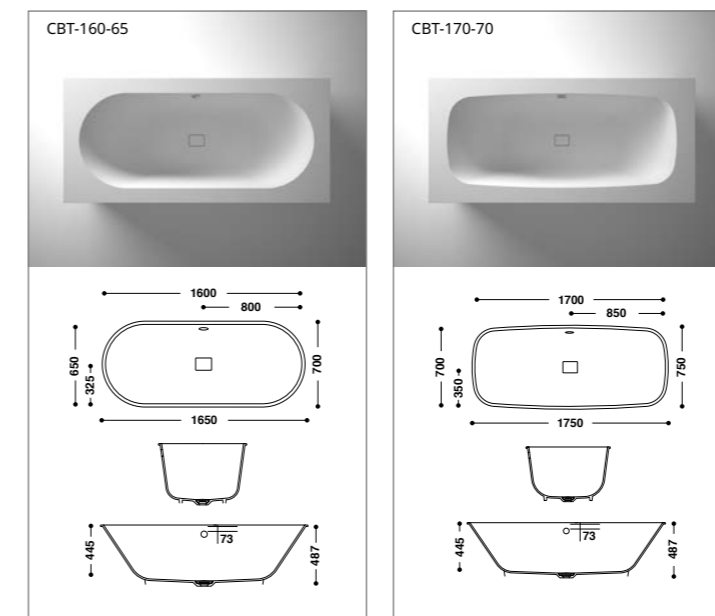

HIMACS Baths

Alongside washbasins, the bath is the central element of a beautifully designed bathroom. And now both are available in the same material: sleek, but also functional, in a useful, aesthetic unit. All baths are designed for integrated installation. The bath is inserted flush-mounted within the panel, so that visually the product is seamless: no visible joints and therefore easy to maintain with hygienic surfaces. The new baths from HIMACS are the perfect way to complete the range and make it more than just a bathroom – they transform it into an all-round feel-good experience.

- Please note:**

 1. The delivery includes either the bath or shower tray (as shown in the sketch) and the matching installation material consisting of height-adjustable feet, a sound-insulating mat and a wooden stabilisation board.
 2. Sheet material is also needed to create the installation seen in the photos.

Please feel free to contact us
for further information.

HIMACS. Because Quality Wins.

European Headquarters:
LX Hausys Europe GmbH
Lyoner Str. 15
60528 Frankfurt
Germany
info@himacs.eu

To find the contact for your region, please visit our website.

[himacs.eu](https://www.himacs.eu)



HIMACS and HIMACS Exteria® are registered trademarks of LX Hausys Europe GmbH. All other trademarks and product names are trademarks or registered trademarks of their respective rights owners. The information contained in this brochure is intended to be for information only and can be amended at any time without prior notification. ©2023. LX Hausys Europe GmbH. All rights reserved.

